

# GCVx145

*Vertical shaft gasoline engine*



*Moteur à essence à arbre de prise de force vertical*

*Benzinmotor mit vertikaler Kurbelwelle*

*Motore a benzina ad albero verticale*

*Bensinmotor med vertikal axel*

*Benzinemotor met verticale uitgaande as*

# GCVx145

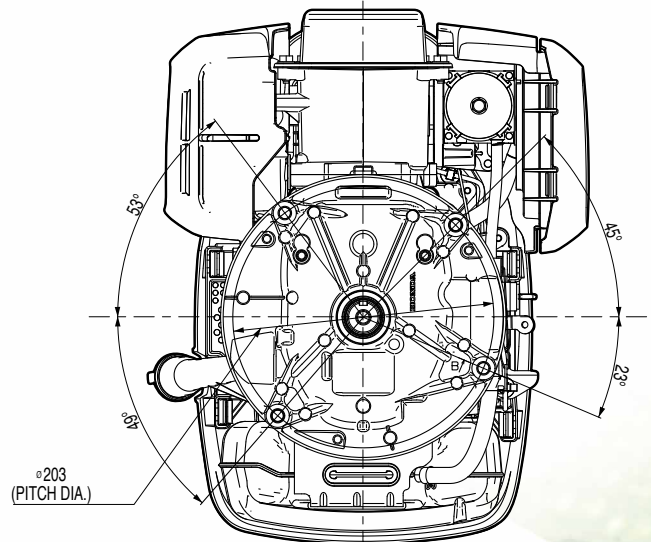
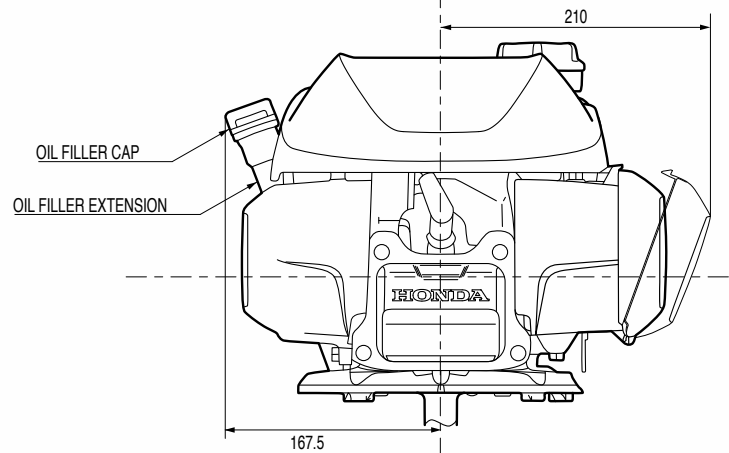
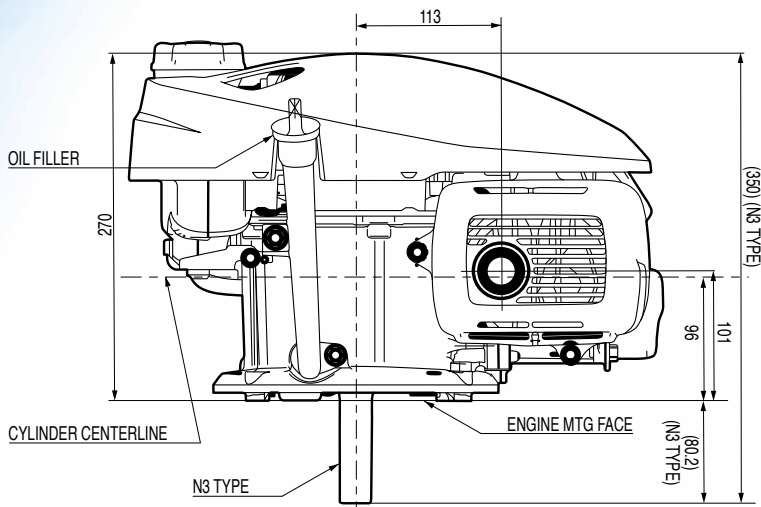
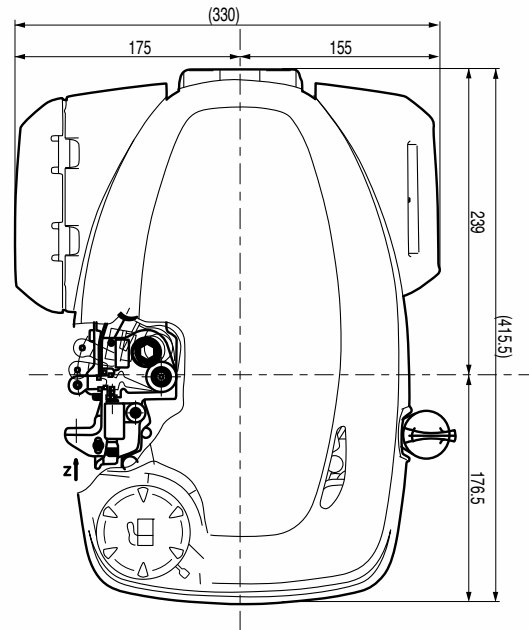
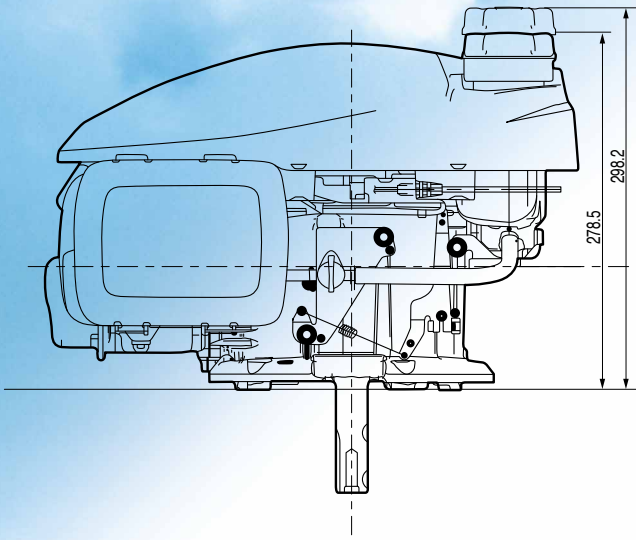

## PTO SHAFT DIMENSIONS

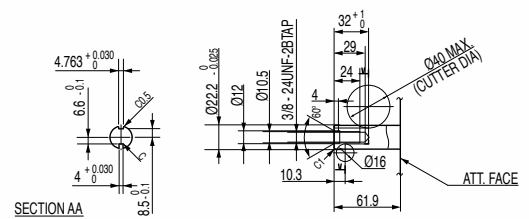
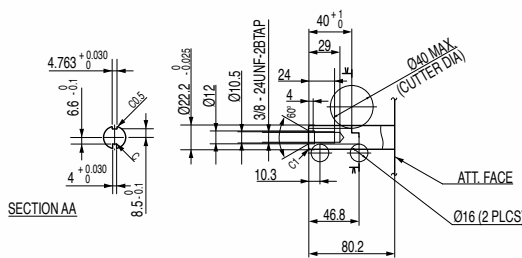

N1-TYPE	N2-TYPE
N3-TYPE	N4-TYPE

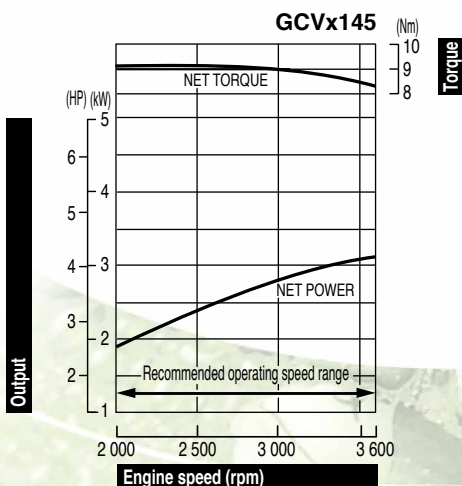
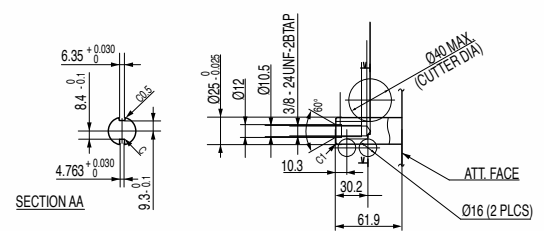
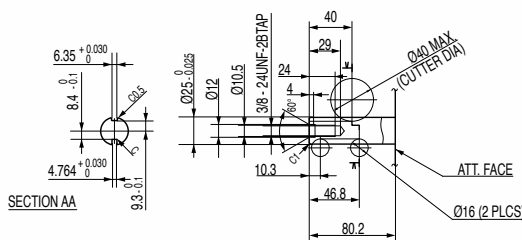

The power rating of the engine indicated in this document is the net power tested on a production engine for the engine model and measured in accordance with SAE J1349 at a specified rpm. Mass production engines may vary from this value. Actual power output for the engine installed in the final machine will vary depending on numerous factors, including the operating speed of the engine in application, environmental conditions, maintenance, and other variables.

La potenza indicata in questo documento, è la potenza netta rilevata su questo modello di motore in fase di produzione, ed è stata misurata secondo la procedura SAE J1349 ad un numero di giri specifico. Nella produzione di massa si possono riscontrare variazioni rispetto a questi valori. La potenza del motore installato nella macchina può dipendere da numerosi fattori, incluso il numero di giri al quale il motore è impiegato, le condizioni ambientali, dal livello di manutenzione ed altre variabili.

La puissance du moteur indiquée dans ce document est une puissance nette obtenue par l'essai d'un moteur de série selon la norme SAE J 1349 à une vitesse de rotation donnée. La puissance d'un autre moteur de production peut être différente de cette valeur indiquée. La puissance réelle d'un moteur installé sur une machine dépendra de différents facteurs comme la vitesse de rotation, les conditions de température, d'humidité, de pression atmosphérique, de maintenance et autres.

De bepaling van het vermogen van de motor, vermeld in dit document, is het netto vermogen getest op een productiemotor en gemeten in overeenstemming met SAE J1349 aan een specifieke t/min. Motoren van massaproductie kunnen van deze waarde variëren. Het werkelijke vermogen van de geïnstalleerde motor in het eindproduct kan afwijken, afhankelijk van talrijke factoren, zoals de operationele snelheid van de motor in een applicatie, omgevingsfactoren, onderhoud en andere variabelen.

Die Leistungsangabe der in diesem Dokument aufgeführten Motoren ist die Netto-Leistung gemäß SAE J1349, getestet bei einer definierten Drehzahl an einem Produktionsmotor. Bei Motoren aus Serienproduktion kann der Wert abweichen. Die Leistungsabgabe in einem Fertigerät weicht, bedingt durch unterschiedliche Faktoren, wie Motordrehzahl in der Applikation, Umwelteinflüsse, Grad der Instandhaltung und andere Einflüsse ab.

Den i detta dokument nämnda motors effekt, är uppmätt i netto effekt. I enlighet med mätmetoden SAE J1349. Massproducerade motorer kan avvika från nämnda värde. Den faktiska effekten för varje motor kan variera beroende på bl a. varvtal, yttre omgivning, underhåll, typ av applikation, mm.

Specifications

Model	GCVx145
Engine type	Air cooled 4-stroke OHV gasoline engine, vertical shaft, aluminium cylinder
Bore x stroke	56 x 59 mm
Displacement	145 cm <sup>3</sup>
Compression ratio	7.7 : 1
Net power	3.1 kW (4.2 HP) / 3 600 rpm
Cont. rated power	2.1 kW (2.8 HP) / 3 000 rpm
Max. net torque	9.1 Nm / 0.93 kgfm / 2 500 rpm
Ignition system	Transistorized
Starting system	Recoil starter
Aircleaner type	Paper
Fuel tank capacity	0.91 l
Fuel cons. at cont. rated power	1.1 l/hr - 3 000 rpm
Engine oil capacity	0.40 l
Dimensions (L x W x H)	415 x 330 x 359 mm
Dry weight	10,1 kg

Spezifikationen

Modell	GCVx145
Motortyp	Luftgekühlter 1-Zylinder 4-Takt OHV Benzinmotor, vertikale Kurbelwelle, Aluminiumzylinder
Bohrung x Hub	56 x 59 mm
Hubraum	145 cm <sup>3</sup>
Verdichtung	7.7 : 1
Netto-Leistung	3.1 kW (4.2 HP) / 3 600 min <sup>-1</sup>
Max. Dauerleistung	2.1 kW (2.8 HP) / 3 000 min <sup>-1</sup>
Max. Netto-Drehmoment	9.1 Nm / 0.93 kgfm / 2 500 min <sup>-1</sup>
Zündsystem	Elektronische Zündung
Starter	Zugstarter
Luftfilter	Papier
Tankinhalt	0.91 Liter
Benzinverbrauch bei Dauerleistung	1.1 l/h - 3 000 min <sup>-1</sup>
Motorölkapazität	0.40 Liter
Maße (L x B x H)	415 x 330 x 359 mm
Trockengewicht	10,1 kg

Specificaties

Model	GCVx145
Motortype	Luchtgekoelde 4-takt OHV benzinemotor, verticale uitgaande as, aluminium cilinder
Boring x slag	56 x 59 mm
Cilinderinhoud	145 cm <sup>3</sup>
Compressie	7.7 : 1
Netto vermogen	3.1 kW (4.2 HP) / 3 600 t/min
Continu nominaal vermogen	2.1 kW (2.8 HP) / 3 000 t/min
Max. netto koppel	9.1 Nm / 0.93 kgfm / 2 500 t/min
Ontsteking	Electronische ontsteking
Startsysteem	Repeteerstarter
Type luchtfilter	Papier
Tankinhoud	0.91 Liter
Brandstofverbruik aan cont. nominaal vermogen	1.1 l/u - 3 000 t/min
Motoroliecapaciteit	0.40 Liter
Afmetingen (L x B x H)	415 x 330 x 359 mm
Drooggewicht	10,1 kg

Spécifications techniques

Modèle	GCVx145
Type du moteur	Moteur à essence monocylindre 4 temps OHV, refroidissement à air, arbre de prise de force vertical, cyl. en alliage d'aluminium
Alésage x course	56 x 59 mm
Cylindrée	145 cm <sup>3</sup>
Taux de compression	7.7 : 1
Puissance nette	3.1 kW (4.2 HP) / 3 600 tr/mn
Puissance en service continu	2.1 kW (2.8 HP) / 3 000 tr/mn
Couple maximum	9.1 Nm / 0.93 kgfm / 2 500 tr/mn
Système d'allumage	Transistorisé
Système de démarrage	Lanceur à rappel
Type du filtre à air	Papier
Cap. du réservoir d'ess.	0.91 l
Consommation de carburant en service continu	1.1 litre(s)/heure - 3 000 tr/mn
Capacité d'huile moteur	0.40 l
Dimensions (L x l x H)	415 x 330 x 359 mm
Poids à sec	10,1 kg

Dati tecnici

Tipo	GCVx145
Tipo di motore	Motore monocilindrico OHV ad albero verticale, ciclo otto, 4 tempi, raffreddamento ad aria forzata, cilindro in alluminio
Alesaggio x corsa	56 x 59 mm
Cilindrata	145 cm <sup>3</sup>
Rapporto di compressione	7.7 : 1
Potenza netta	3.1 kW (4.2 HP) / 3 600 giri/min
Potenza nominale continua	2.1 kW (2.8 HP) / 3 000 giri/min
Coppia massima	9.1 Nm / 0.93 kgfm / 2 500 giri/min
Accensione	A transistor senza contatti
Avviamento	Autoavvolgente
Sistema filtro aria	A secco
Capacità serbatoio	0.91 Litri
Consumo di combustibile alla potenza continuativa	1.1 Litri/ora - 3 000 giri/min
Capacità coppa olio	0.40 Litri
Dimensioni (Lu x La x A)	415 x 330 x 359 mm
Peso a secco	10,1 kg

Specificationer

Modell	GCVx145
Motortyp	Luftkyld 4-takts bensinmotor med överliggande ventiler, Vertikal axel, aluminium cylinder
Cylinderdiameter x slaglängd	56 x 59 mm
Slagvolym	145 cm <sup>3</sup>
Kompressionsförhållande	7.7 : 1
Netto effekt	3.1 kW (4.2 HP) / 3 600 varv per minut
Rek. kontinuerlig effekt	2.1 kW (2.8 HP) / 3 000 varv per minut
Max. netto vridmoment	9.1 Nm / 0.93 kgfm / 2 500 varv per minut
Tändsystem	Transistor
Startsystem	Startapparat
Typ av luftrenare	Papper
Tankvolym	0.91 Liter
Bränsleförbrukning vid kontinuerlig märkeffekt	1.1 l/tim - 3 000 varv per minut
Oljjevolym	0.40 Liter
Dimensioner (L x B x H)	415 x 330 x 359 mm
Torrsvikt	10,1 kg

All specifications are subject to change without notice. Les caractéristiques techniques peuvent être modifiées à tout moment et sans préavis. Spécifikationen kan ändras utan föregående meddelande.

Le specifiche sono soggette a cambiamento senza preavviso. Die Spezifikationen können ohne Vorankündigung geändert werden. Die Specificationer kunnen en zonder kennisgeving gewijzigd worden.

**HONDA**

**Honda Motor Europe Logistics NV**

Langerbruggestraat 104  
B-9000 Gent  
TEL: + 32 (0)9 250 12 11

[www.honda-engines-eu.com](http://www.honda-engines-eu.com)

**Honda Engines - France**

Honda Motor Europe Ltd Succursale France • Parc d'Activités de Pariest • Allée du 1<sup>er</sup> Mai, BP 46 • Croissy Beaubourg F-77312 Marne-la-Vallée Cedex 2 • TEL: + 33 (0)1 60 37 32 45

**Honda Engines - Germany**

Honda Deutschland Ndl. der HME Ltd. • Hanauer Landstraße 222-224 • D-60314 Frankfurt  
TEL: + 49 69 8309-365

**Honda Engines - Italy**

Honda Motor Europe Logistics NV • Via Maestri del Lavoro 1 • I - 37068 Vigasio (VR)  
TEL: + 39 045 6173341

**Honda Engines - Sweden**

Honda Motor Europe Ltd Filial Sverige • Box 31002 • SE-200 49 Malmö  
TEL: + 46 40 38 07 18

**Honda Engines - United Kingdom**

Honda Motor Europe Logistics NV • Viscount Way, South Marston Park • Swindon SN3 4TN, UK  
TEL: + 44 (0) 1455 559429

**Honda Engines - Russia**

Representative office of Honda Motor Europe Logistics in Russia  
Building 1, Pridorozhnaya Street, Sharapovo settlement, Marushkinsky District • 108809 Moscow, Russian Federation  
TEL: + 7 (495) 2288123