

GCV 190

Vertical shaft gasoline (petrol) engine



Moteur à essence à arbre de prise de force vertical

Benzinmotor mit vertikaler Kurbelwelle

Motore a benzina ad albero verticale

Bensinmotor med vertikal axel

Benzinemotor met verticale uitgaande as

GCV 190

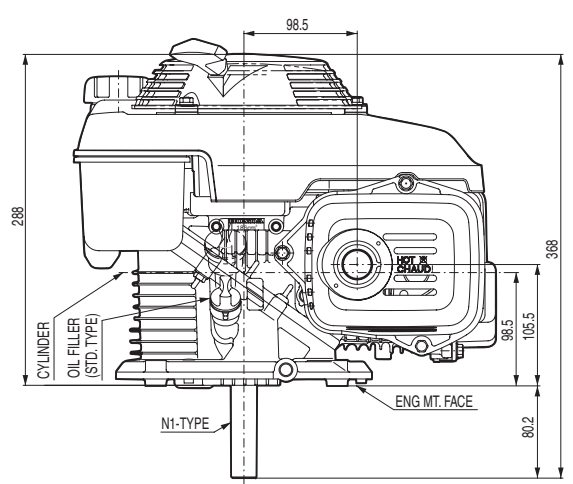
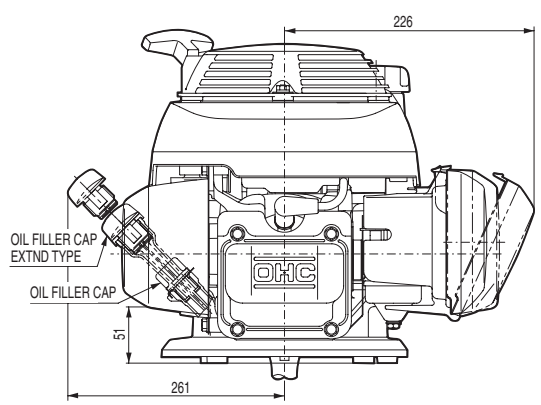
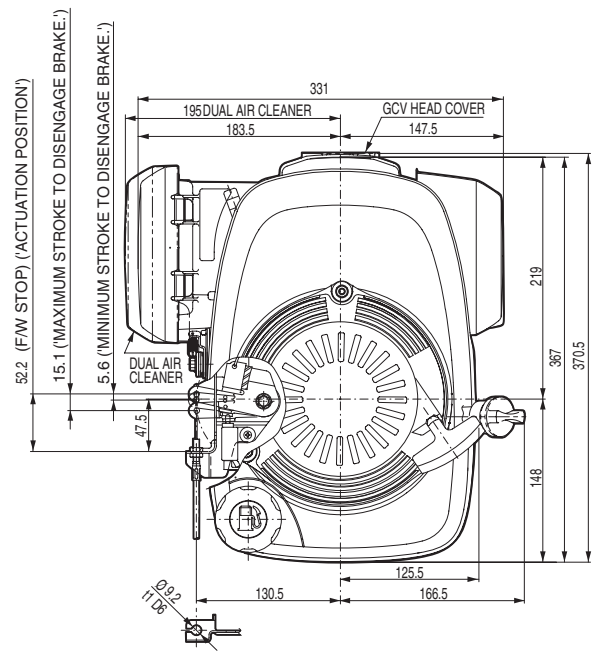
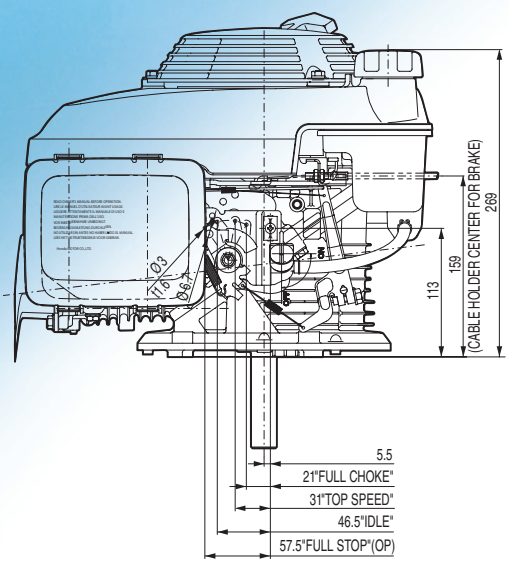

Specifications

Model	GCV 190
Engine type	Air cooled 4-stroke OHC petrol engine, vertical shaft, aluminium cylinder
Bore x stroke	69 x 50 mm
Displacement	187 cm ³
Compression ratio	8.5 : 1
Net power	3.8 kW (5.1 HP) / 3 600 rpm
Cont. rated power	2.6 kW (3.5 HP) / 3 000 rpm
Max. net torque	11.3 Nm / 1.15 kgfm / 2 500 rpm
Ignition system	Transistorised
Starting system	Recoil or electric start
Aircleaner type	Paper
Fuel tank capacity	0.91 l
Fuel cons. at rated power	1.3 L/hr - 3 000 rpm
Engine oil capacity	0.55 l
Dimensions (L x W x H)	367 x 331 x 368 mm
Dry weight	12.3 kg

Spezifikationen

Modell	GCV 190
Motortyp	Luftgekühlter 1-Zylinder 4-Takt OHC Benzinmotor, vertikale Kurbelwelle, Aluminiumzylinder
Bohrung x Hub	69 x 50 mm
Hubraum	187 cm ³
Verdichtung	8.5 : 1
Netto-Leistung	3.8 kW (5.1 HP) / 3 600 min ⁻¹
Max. Dauerleistung	2.6 kW (3.5 HP) / 3 000 min ⁻¹
Max. Netto-Drehmoment	11.3 Nm / 1.15 kgfm / 2 500 min ⁻¹
Zündsystem	Elektronische Zündung
Starter	Reversierstarter oder elektrostarter
Luftfilter	Papier
Tankinhalt	0.91 Liter
Benzinverbrauch bei Dauerleistung	1.3 L/h - 3 000 min ⁻¹
Motorölkapazität	0.55 Liter
Maße (L x B x H)	367 x 331 x 368 mm
Trockengewicht	12.3 kg

Specificaties

Model	GCV 190
Motortype	Luchtgekoelde 4-takt OHC benzinmotor, verticale uitgaande as, aluminium cilinder
Boring x slag	69 x 50 mm
Cilinderinhoud	187 cm ³
Compressie	8.5 : 1
Netto vermogen	3.8 kW (5.1 HP) / 3 600 t/min
Continu nominaal vermogen	2.6 kW (3.5 HP) / 3 000 t/min
Max. netto koppel	11.3 Nm / 1.15 kgfm / 2 500 t/min
Ontsteking	Electronische ontsteking
Startsysteem	Terugslag of elektrische start
Type luchtfilter	Papier
Tankinhoud	0.91 Liter
Brandstofverbruik aan nominaal vermogen	1.3 l/u - 3 000 t/min
Motoroliecapaciteit	0.55 Liter
Afmetingen (L x B x H)	367 x 331 x 368 mm
Drooggewicht	12.3 kg

Spécifications techniques

Modèle	GCV 190
Type du moteur	Moteur à essence monocylindre 4 temps OHC, refroidissement à air, arbre de prise de force vertical, cyl. en alliage d'aluminium
Alésage x course	69 x 50 mm
Cylindrée	187 cm ³
Taux de compression	8.5 : 1
Puissance nette	3.8 kW (5.1 HP) / 3 600 tr/mn
Puissance en service continu	2.6 kW (3.5 HP) / 3 000 tr/mn
Couple maximum	11.3 Nm / 1.15 kgfm / 2 500 tr/mn
Système d'allumage	Transistorisé
Système de démarrage	Lanceur à retour automatique ou démarreur électrique
Type du filtre à air	Papier
Cap. du réservoir d'ess.	0.91 l
Consommation de carburant en service continu	1.3 litre(s)/heure - 3 000 tr/mn
Capacité d'huile moteur	0.55 l
Dimensions (L x l x H)	367 x 331 x 368 mm
Poids à sec	12.3 kg

Dati tecnici

Tipo	GCV 190
Tipo di motore	Motore monocilindrico OHC ad albero verticale, ciclo otto, 4 tempi, raffreddamento ad aria forzata, cilindro in alluminio
Alesaggio x corsa	69 x 50 mm
Cilindrata	187 cm ³
Rapporto di compressione	8.5 : 1
Potenza netta	3.8 kW (5.1 HP) / 3 600 giri/min
Potenza nominale continua	2.6 kW (3.5 HP) / 3 000 giri/min
Coppia massima	11.3 Nm / 1.15 kgfm / 2 500 giri/min
Accensione	A transistor senza contatti
Avviamento	A strappo con autoavvolgente / Elettrico (per alcune versioni)
Sistema filtro aria	A secco
Capacità serbatoio	0.91 Litri
Consumo combustibile alla potenza nominale	1.3 Litri/ora - 3 000 giri/min
Capacità coppa olio	0.55 Litri
Dimensioni (Lu x La x A)	367 x 331 x 368 mm
Peso a secco	12.3 kg

Specifikationer

Modell	GCV 190
Motortyp	Luftkyld 4-takts bensinmotor med överliggande kamaxel, Vertikal axel, aluminium cylinder
Cylinderdiameter x slaglängd	69 x 50 mm
Slagvolym	187 cm ³
Kompressionsförhållande	8.5 : 1
Netto effekt	3.8 kW (5.1 HP) / 3 600 varv per minut
Rek. kontinuerlig effekt	2.6 kW (3.5 HP) / 3 000 varv per minut
Max. netto vridmoment	11.3 Nm / 1.15 kgfm / 2 500 varv per minut
Tändsystem	Transistor
Startsystem	Manuellt eller elektrisk start
Typ av luftrenare	Papper
Tankvolym	0.91 Liter
Bränsleförbrukning vid märkeffekt	1.3 L/tim - 3 000 varv per minut
Oljevolym	0.55 Liter
Dimensioner (L x B x H)	367 x 331 x 368 mm
Torrsvikt	12.3 kg

All specifications are subject to change without notice.
Les caractéristiques techniques peuvent être modifiées à tout moment et sans préavis.
Spesifikationer kan ändras utan föregående meddelande.

Le specifiche sono soggette a cambiamento senza preavviso.
Die Spezifikationen können ohne Vorankündigung geändert werden.
Alle technische specificaties kunnen op elk ogenblik en zonder kennisgeving gewijzigd worden.

Le specifiche sono soggette a cambiamento senza preavviso.
Die Spezifikationen können ohne Vorankündigung geändert werden.
Alle technische specificaties kunnen op elk ogenblik en zonder kennisgeving gewijzigd worden.

HONDA

ENGINES

Honda Europe NV
EUROPEAN ENGINE CENTER
Langerbrugstraat 104
B-9000 Gent
TEL: + 32 (0)9 250 12 11
FAX: + 32 (0)9 250 14 24

www.honda-engines-eu.com

Honda Engines - France

Honda Motor Europe (South) S.A. • Parc d'Activités de Pariest • Allée du 1^{er} Mai, BP 46 • Croissy Beaubourg • F-77312 Marne-la-Vallée Cedex 2
TEL: + 33 (0)1 60 37 30 16 • FAX: + 33 (0)1 60 37 33 66

Honda Engines - Germany

Honda Motor Europe (North) GmbH • Spremlinger Landstraße 166 • D-63069 Offenbach/Main
TEL: + 49 (0)6 98 30 93 65 • FAX: + 49 (0)6 98 30 91 28

Honda Engines - Italy

Honda Logistic Centre Italy S.p.A. • Via Strà 153-154 • I-37030 Colognola ai Colli (VR)
TEL: + 39 045 6173341 • FAX: + 39 045 6151270

Honda Engines - Sweden

Honda Logistics Center Sweden AB • Box 50583 Västkvägen 17 • SE-20215 Malmö
TEL: + 46 40 38 07 00 • FAX: + 46 40 38 07 88

Honda Engines - United Kingdom

Honda Logistics Centre (UK) Ltd. • Viscount Way, South Marston Park • Swindon SN3 4TN, UK
TEL: + 44 (0)1 455 559429 • FAX: + 44 (0)1 455 559428