

Robin Industrial Engines®

PARTS MANUAL

Model

DY41

1193P232



ROBIN AMERICA, INC.
ROBIN TO WISCONSIN ROBIN
ENGINE MODEL CROSS REFERENCE LIST

ROBIN

WISCONSIN ROBIN

SIDE VALVE

EY08	W1-080
EY15	W1-145
EY15V	W1-145V
EY20	W1-185
EY20V	W1-185V
EY23	W1-230
EY28	W1-280
EY35	W1-340
EY40	W1-390
EY45V	W1-450V
EY21	EY21W
EY44	EY44W
EY18-3	EY18-3W
EY25	EY25W
EY27	EY27W

OVERHEAD VALVE

EH11	W01-115
EH12	W01-120
EH15	W01-150
EH17	W01-170
EH21	W01-210
EH25	W01-250
EH30	W01-300
EH30V	W01-300V
EH34	W01-340
EH34V	W01-340V
EH43V	W01-430V

TWO CYCLE

EC13V	WT1-125V
-------	----------

DIESEL

DY23	WRD1-230
DY27	WRD1-270
DY30	WRD1-300
DY35	WRD1-350
DY41	WRD1-410

HOW TO USE THIS PARTS CATALOG

All Robin Industrial Engines have a Production number to identify their specification. The Production number is a 15 digit, alphanumeric number. The first 11 digits are classified as the specification number of the engine. The last 4 digits are the manufacturing code. An example is shown below:

(PRODUCTION NUMBER)	
<u>EY400DD1650</u>	<u>XXXX</u>
(SPECIFICATION #)	(CODE)

All 15 digit production numbers will be located in one of the following locations depending upon the engine model. The number will either be stamped onto a cylinder baffle or attached to one of the other locations by an easily visible label.

MARKING LOCATIONS OF PRODUCTION NUMBER

PROD.No.

How to check PROD. No.

PROD.No.(背番号)は、下記により確認して下さい。

Check PROD. No. as illustrated below.

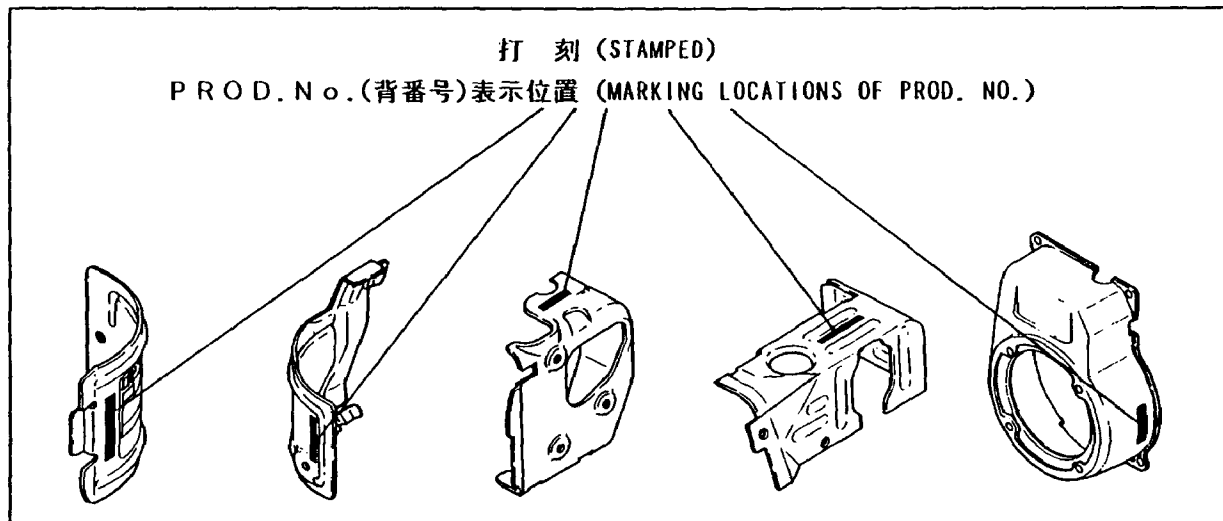

PROD.No.(背番号)15桁は、シリンダーバッフル上に打刻、又はブローハウジングなど見易い位置にラベルの貼付など、いずれかで表示されています。

PROD.No. with 15 characters is marked either by stamping on the cylinder baffle or by sticking label to easily visible locations such as on the blower housing.

PROD.No.(背番号)
表示例
Marking example

PROD.No.○○△△△□□□□□××××

PROD.No.○○△△△□□□□□
××××

How to find the part of your need

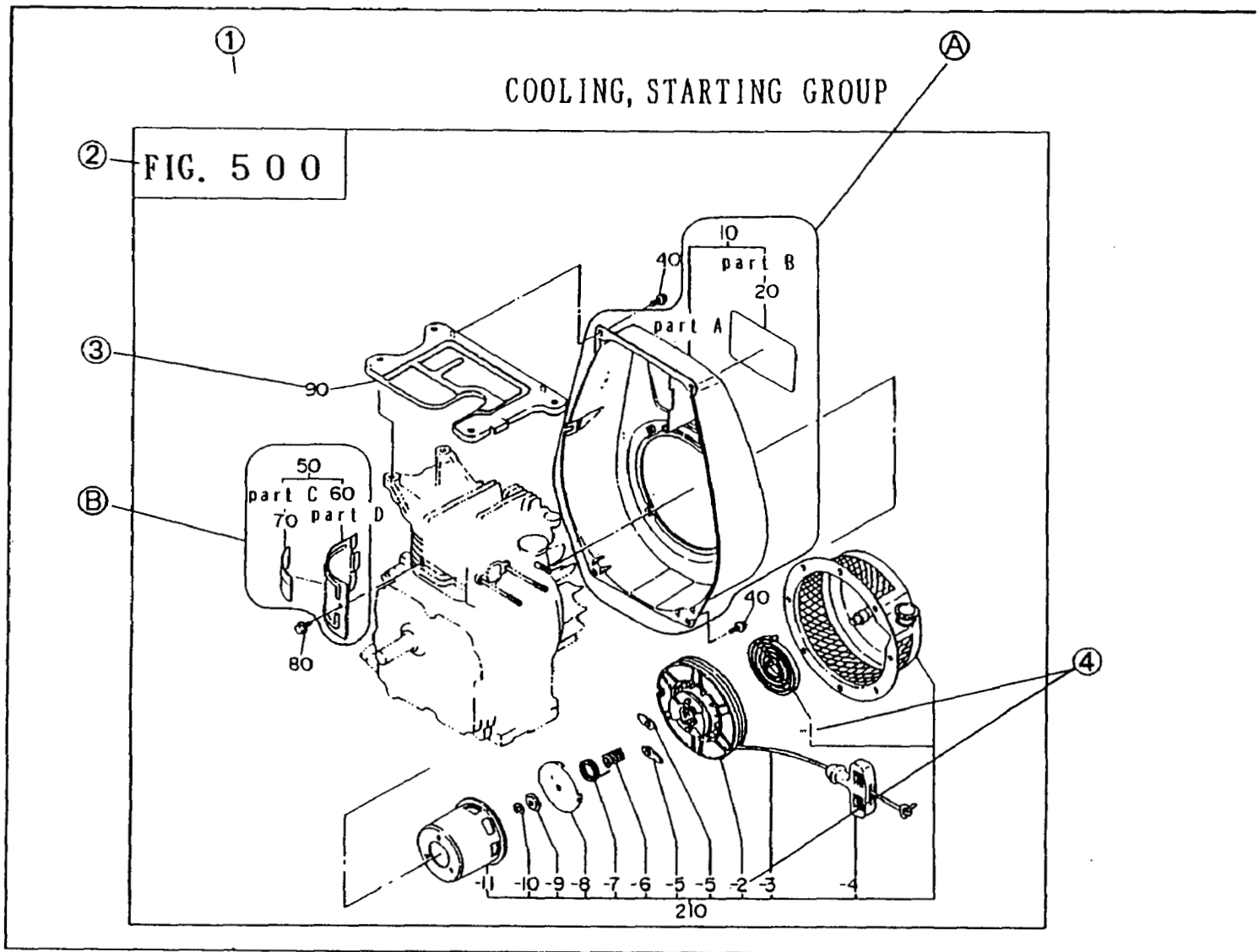

NOTE: Some of the parts shown may be somewhat different from their actual shape and location. The illustrations of this catalog are intended to assist in ordering the correct part(s).

{TERMS}

(1) Group..... Parts are classified into functional groups. Refer to the group index for specific groups.

(2) Fig. No.Indicates illustration number and corresponds to the FIG. NO. in the list.

(3) Ref. No. Corresponds to Ref. No. in parts list.

Example A.... The part indicated by Ref. No. 10 consists of part A and B. Part A is available either in the form of an assembly, Ref. No. 10(A_Y), or as a complete unit, A (CP). Part B is available as a part by itself.

Example B.....Parts C and D are available either as an assembly, Ref. No. 50(A_Y) or as a complete unit, (CP). Both parts are available as a part by itself.

(4) Sub-divided Ref. No.....Refers to a separate part within a group that is available as an independent part.

COOLING, STARTING GROUP

REF NO.	部品番号 PART NUMBER	部品名称 PART NAME	数量 QTY	備 考 RE M A R K S	管理番号 CODE NO. FROM-TO	小売単価 UNIT PRICE	FIG. NO.
③ 10	234-51201-01	ブローホウジング CP BLOWER HOUSING CP	1	D,DS形用 for D,DS type	-	-	500
	234-51101-01	ブローホウジング CP BLOWER HOUSING CP	1		B,BS形用 for B,BS type	-	-
20	234-91701-03	ラベル(トレードマーク) シリンダースタック CP LABEL (TRADE MARKE) CYLINDER BAFFLE CP	1		-	-	500
⑤ 60	234-52602-01	シリンダースタック CP CYLINDER BAFFLE CP	1		-	-	500
	234-52601-03	シリンダースタック CYLINDER BAFFLE	1		-	-	500
70	234-91802-03	ラベル,エンジンネーム LABEL, ENGINE NAME	1		-	-	500
80	011-00600-20	フランジボルト FLANGE BOLT	1		-	-	500
90	234-52701-23	ヘッドカバー HEAD COVER	1	X ○ ○ ○ X	0091-	-	500
	234-52701-13	ヘッドカバー HEAD COVER	1		0001-0090	-	500
	234-52701-03	ヘッドカバー HEAD COVER	1		-0000	-	500
	234-52700-13	ヘッドカバー HEAD COVER	1		E/C NO. 1002994-	-	500
	234-52700-03	ヘッドカバー HEAD COVER	1		-	-	500
210	234-50211-00	リコイルスターター AY RECOIL STARTER AY	1		-	-	500
-1	106-50116-08	スパイラルスプリング SPIRAL SPRING	1		-	-	500
④ -2	207-50122-18	リール CP REEL CP	1		-	-	500

(5) Part No.....Part number assigned to part used in the applicable product. Is the number to be ordered.

(6) Part Name..Brief description of part number..

(7) Quantity....Number of parts required for particular part number in applicable product.

(8) Remarks....Additional information (if applicable) required for applicable product.

(9) Code No... Indicates modification records and provides identification of the part used in the items with Production No. by referring to the Code No.

Example (C)

[-] The part has been continuously used in the applicable product regardless of Code No.

Example (D)

[0091-] Part used in the products with code number after 0091.

[0001-0091] Part used in the products with code number between 0001 - 0091.

[- 0000] Part used in the products with code number before 0000.

(10) Unit Price..Refer to Robin America published Parts Price Catalog for pricing.

[Note] Information on parts for Engines with a Code Number before 0001 and without a Production No. stamped on the engines are available by providing the engine serial number found stamped on the crankcase of the engine.

GROUP INDEX

GROUP NAME	FIG. NO.	PAGE
CRANKCASE	100	2
CRANK, PISTON.....	200	6
OPTIONAL EQUIPMENT	210	8
INTAKE, EXHAUST.....	300	10
MUFFLER & AIR CLEANER	310	12
GOVERNOR, OPERATE	400	14
COOLING, STARTING.....	500	16
FUEL, LUBRICANT	600	18
ELECTRIC DEVICE	700	22
ACCESSORIES, LABEL	900	28

Fig. 100

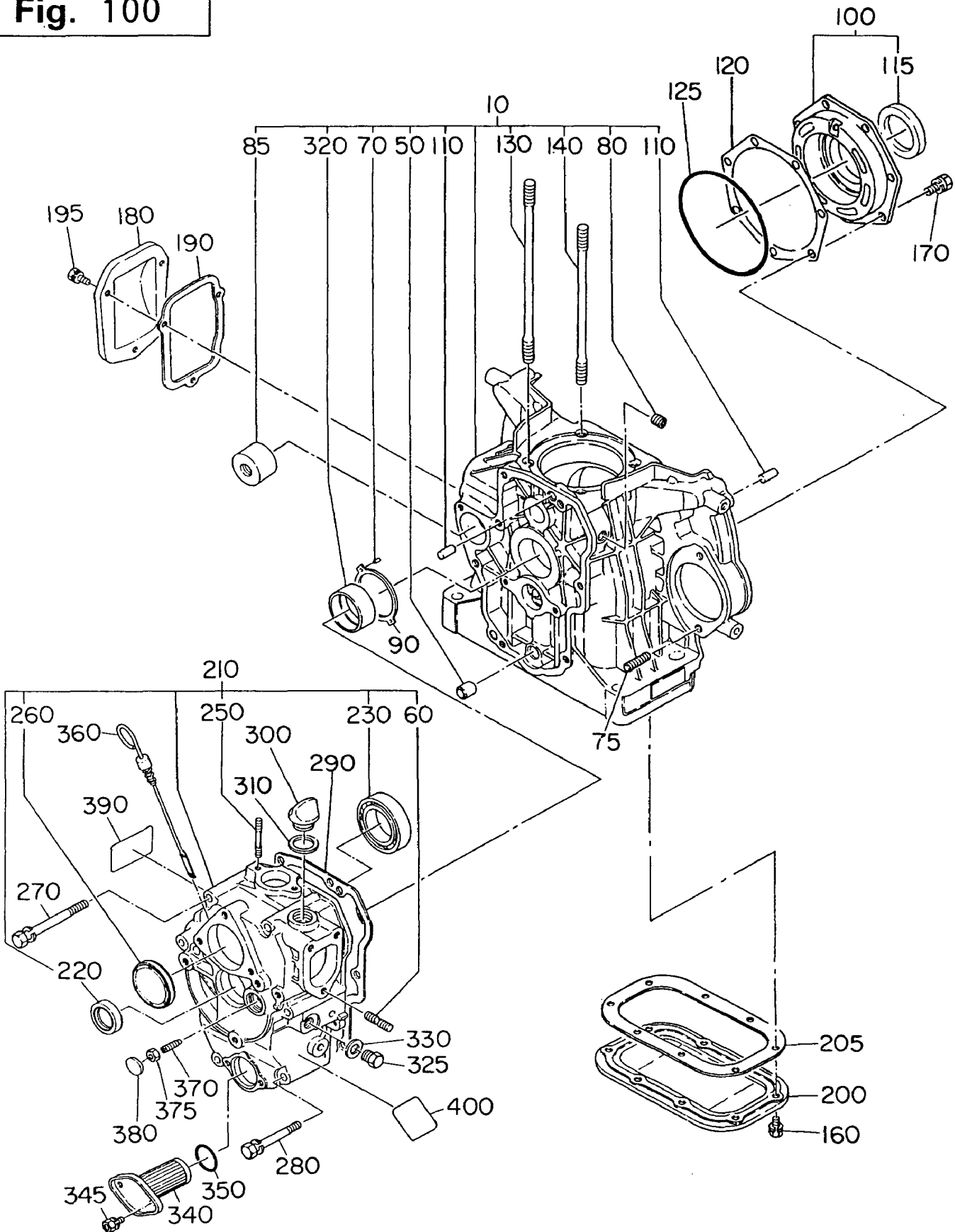

CRANKCASE

93/09/21

REF. NO.	PART NUMBER		PART NAME		CODE NO. FROM - TO	QTY	REMARKS	INTERCHANGEABLE PART NUMBER	FIG. NO.
		PART NUMBER		SPEC. NO.					
10	231-10108-11		CRANKCASE CP		-	1			100
		231-10110-01		DY410YS0000	-	1			100
20	228-14202-03		VALVE GUIDE		-	2			100
50	228-15003-13		PIPE KNOCK		-	1			100
60	001-32083-51		STUD		-	3			100
70	005-19250-60		SPRING PIN		-	2			100
75	*****		STUD						
		010-50800-44		DY410YS0000	-	2			100
80	212-15008-13		BLIND PLUG		-	1			100
85	228-25002-03		SLEEVE (BALANCER)		-	1			100
90	228-15002-03		THRUST BEARING		-	1			100
100	231-11501-21		BEARING HOUSING CP		-	1			100
		231-11502-21		DY410YS0000	-	1			100
110	005-26081-80		DOWEL PIN		-	4			100
115	044-04000-20		OIL SEAL		-	1			100
120	231-15004-03		GASKET, BEAR. HOUSING		-	1	T=0.1 SELECTIVE AY		100
		231-15005-03		GASKET, BEAR. HOUSING	-	1	T=0.2 SELECTIVE AY		100
		231-15006-03		GASKET, BEAR. HOUSING	-	1	T=0.3 SELECTIVE AY		100
125	231-15014-03		O RING, BEAR. HOUSING		-	1			100
130	231-16001-11		TENSION BOLT 1 CP		-	2			100
140	231-16002-11		TENSION BOLT 2 CP		-	2			100
160	980-05060-10		BOLT & WASHER AY		-	10			100
170	001-13082-00		BOLT & WASHER AY		-	7			100
180	228-26001-01		BALANCER COVER CP		-	1			100
190	228-25004-03		GASKET (BALANCER COV)		-	1			100
195	980-05060-10		BOLT & WASHER AY		-	3			100
200	231-11601-03		OIL PAN		-	1			100
205	231-15008-03		GASKET (OIL PAN)		-	1			100
210	231-11701-01		GEAR CASE COVER CP		-	1			100
220	044-02200-50		OIL SEAL		-	1			100
230	060-03500-40		BALL BEARING		-	1	BB6007C3		100
250	001-32064-50		STUD		-	2			100
260	041-05000-11		BLIND PLATE		-	1			100
270	001-13088-50		BOLT AND WASHER AY		-	4			100
280	001-13086-50		BOLT AND WASHER AY		-	4			100
290	231-15007-03		GASKET (CASE COVER)		-	1			100

Fig. 100

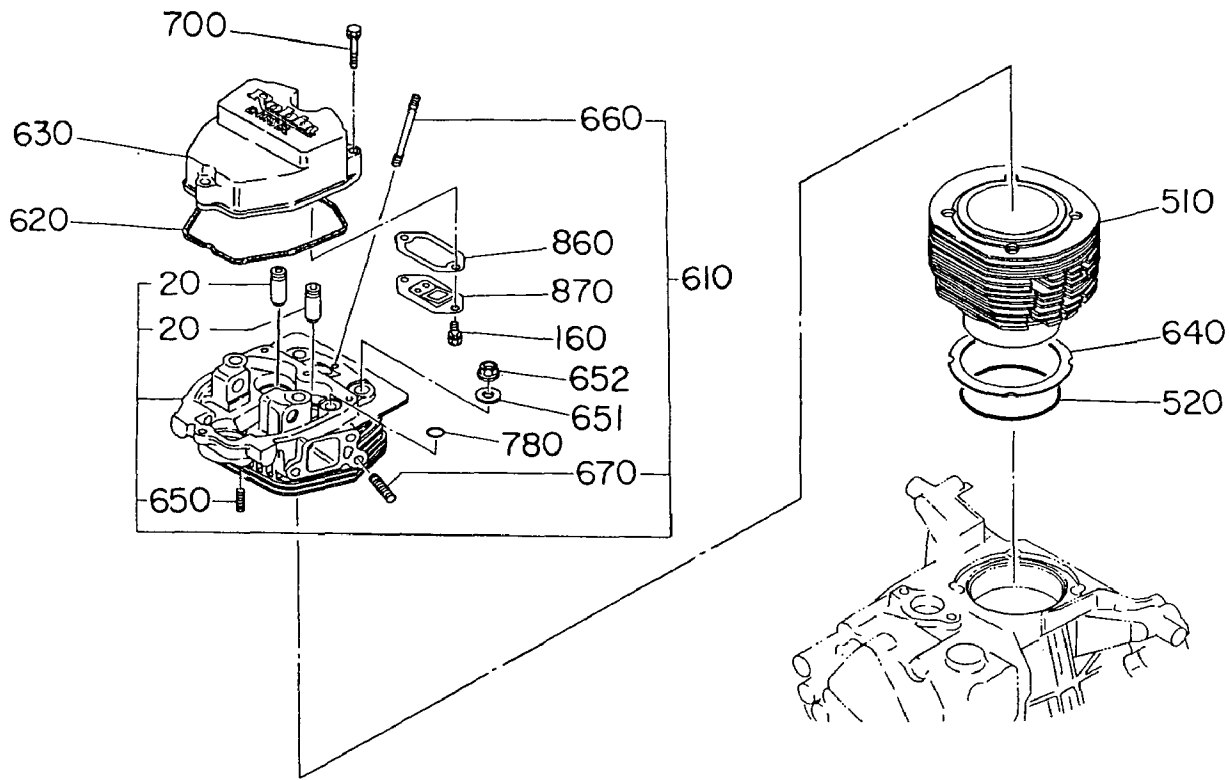

CRANKCASE

93/09/21

REF. NO.	PART NUMBER		PART NAME		CODE NO. FROM - TO	QTY	REMARKS	INTERCHANGEABLE PART NUMBER	FIG. NO.
		PART NUMBER		SPEC. NO.					
300		228-65003-03		PLUG	-	1			100
310		021-32000-10		GASKET	-	1			100
320		228-15801-03		MAIN BEARING STD	-	1	STD		100
		228-15802-03		MAIN BEARING 0.25MM	-	1	UNDER SIZE 0.25		100
		228-15803-03		MAIN BEARING 0.50MM	-	1	UNDER SIZE 0.50		100
325		040-11200-30		PLUG	-	1			100
330		003-70120-00		GASKET, ALUMINUM	-	1			100
340		228-64301-00		OIL FILTER AY	-	1			100
345		980-05060-10		BOLT & WASHER AY	-	2			100
350		024-03000-10		O RING	-	1			100
360		228-63610-01		OIL GAUGE CP	-	1			100
370		014-90600-70		ADJUSTING SCREW	-	1			100
375		002-18060-00		NUT	-	1			100
380		041-12200-10		BLIND PLUG	-	1			100
400		228-92104-03		LABEL (OPERATION)	-	1			100
510		231-12401-02		CYLINDER UN	-	1			100
520		229-15011-03		O RING (CYLINDER)	-	1			100
610		229-13110-11		CYLINDER HEAD CP	-	1			100
620		228-15010-03		GASKET (ROCKER COVER)	-	1			100
630		228-17001-03		ROCKER COVER	-	1			100
640		229-15012-13		SPACER, CYLINDER 0.1	-	1	T=0.1 SELECTIVE AY		100
		229-15013-13		SPACER, CYLINDER 0.2	-	1	T=0.2 SELECTIVE AY		100
650		001-31062-51		STUD	-	2			100
651		980-30110-70		WASHER (11.5X23X4)	-	4		803011070	100
652		018-01000-11		FLANGE NUT	-	4			100
660		010-50601-50		STUD	-	2			100
670		001-37082-01		STUD	-	6			100
700		001-13064-00		BOLT AND WASHER AY	-	3			100
780		024-01300-10		O RING	-	1			100
860		228-15009-23		GASKET (BREATHER)	-	1			100
870		228-15301-01		BREATHER PLATE CP	-	1			100
960		231-99001-07		GASKET SET	-	1			100

CRANK, PISTON GROUP

FIG. 200

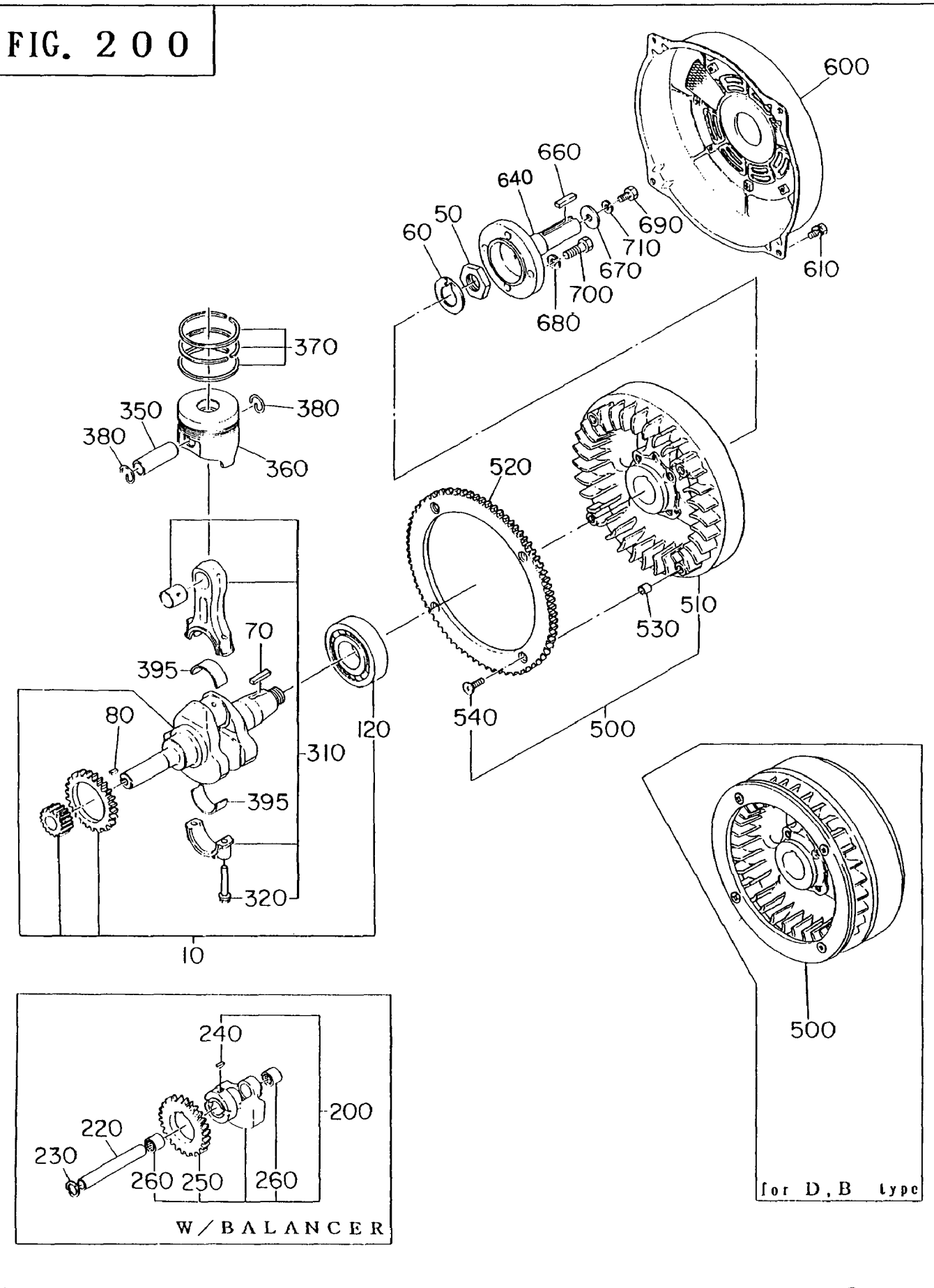

CRANKSHAFT, PISTON

93/09/21

REF. NO.	PART NUMBER		PART NAME		CODE NO. FROM - TO	QTY	REMARKS	INTERCHANGEABLE PART NUMBER	FIG. NO.
		PART NUMBER		SPEC. NO.					
10		231-20202-01		CRANKSHAFT CP	-	1			200
15		005-30040-81		KEY	-	1			200
20		060-04000-30		BALL BEARING	-	1	BB6308C3		200
30		005-30072-01		KEY	-	1			200
50		017-32600-10		LOCK NUT	-	1			200
60		020-52600-12		LOCK WASHER	-	1			200
200		231-24301-11		BALANCER CP	-	1			200
210		231-24202-03		BALANCER GEAR 2	-	1			200
220		061-01500-10		NEEDLE BEARING	-	2			200
230		005-32042-01		WOODRUFF KEY	-	1			200
240		228-24101-03		BALANCER SHAFT	-	1			200
250		003-14150-00		SNAPRING(INNER)	-	1			200
310		231-22501-00		CONNECTING ROD AY	-	1			200
320		231-23001-03		CONNECTING ROD BOLT	-	2			200
350		228-23301-03		PISTON PIN	-	1			200
360		231-23401-33		PISTON	-	1	STD		200
		231-23402-33		PISTON	-	1	OVER SIZE 0.25		200
		231-23403-33		PISTON	-	1	OVER SIZE 0.50		200
370		229-23501-17		PISTON RING SET STD	-	1	STD		200
		229-23502-17		PISTON RING SET 0.25	-	1	OVER SIZE 0.25		200
		229-23503-17		PISTON RING SET 0.50	-	1	OVER SIZE 0.50		200
380		056-52100-10		CRIP	-	2			200
390		228-22801-13		LARGE END BEARING	-	2	STD		200
		228-22802-13		LARGE END BEARING	-	2	UNDER SIZE 0.25		200
		228-22803-13		LARGE END BEARING	-	2	UNDER SIZE 0.50		200
500		228-22401-23		FLYWHEEL	-	1			200
		228-22402-21		DY410YS0000	-	1			200
510		*****		FLYWHEEL					
		228-22402-23		DY410YS0000	-	1			200
520		*****		RING GEAR					
		228-71001-03		DY410YS0000	-	1			200
530		*****		PIPE KNOCK					
		243-15011-03		DY410YS0000	-	2			200
540		*****		SCREW					
		004-11082-50		DY410YS0000	-	4			200
640		228-24406-03		DRIVING SHAFT	-	1			200

FIG. 210

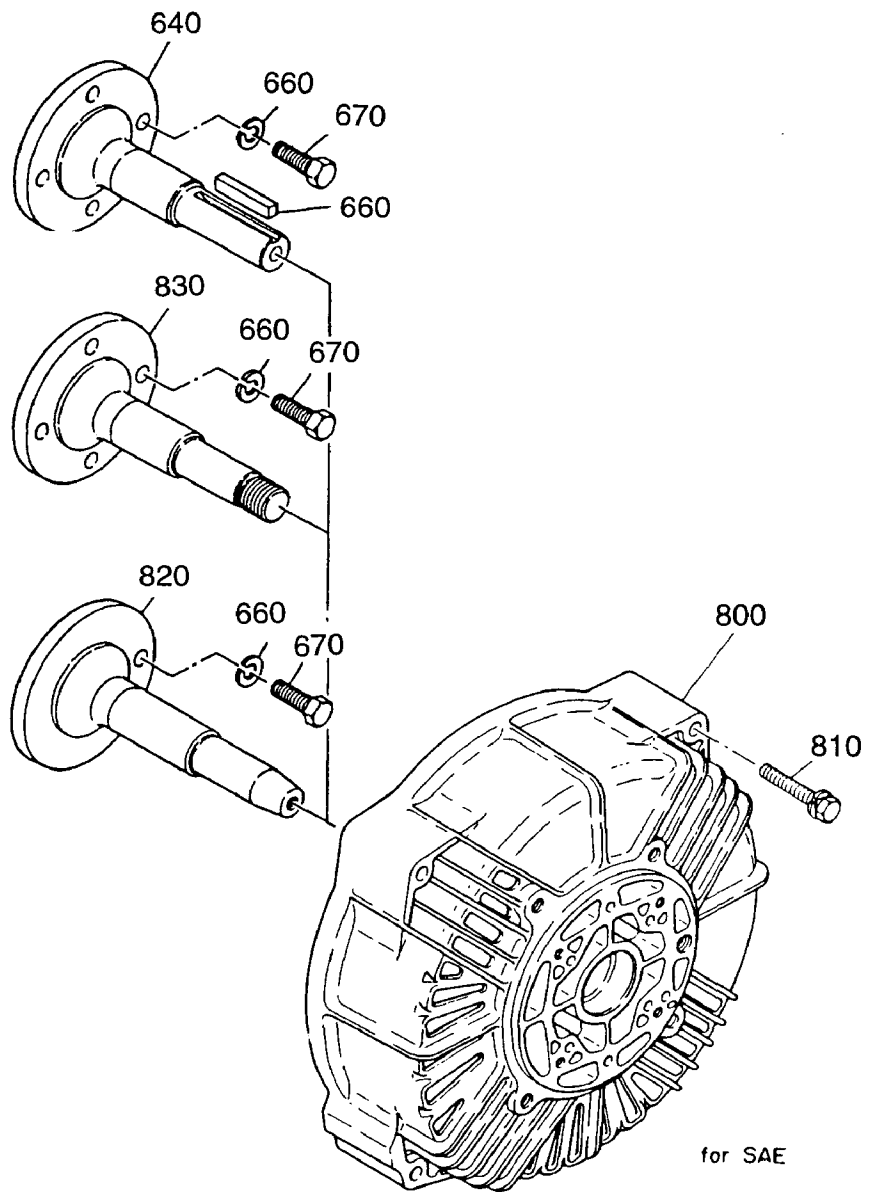

CRANKSHAFT, PISTON

93/09/21

REF. NO.	PART NUMBER		PART NAME		CODE NO. FROM - TO	QTY	REMARKS	INTERCHANGEABLE PART NUMBER	FIG. NO.
		PART NUMBER		SPEC. NO.					
650	207-26001-03		KEY		-	1			200
660	003-20100-00		SPRING WASHER		-	4			200
670	001-67103-00		BOLT		-	4			200
690	228-25501-11		FLYWHEEL COVER CP		-	1			200
700	001-13081-60		BOLT & WASHER AY		-	4			200
800	228-17911-23		ADAPTER		-	1			210
810	001-13086-00		BOLT & WASHER AY		-	4			210
820	228-24407-03		DRIVING SHAFT		-	1	FOR GENERATOR		210
830	228-24408-03		DRIVING SHAFT		-	1	FOR PUMP		210

INTAKE, EXHAUST GROUP

FIG. 300

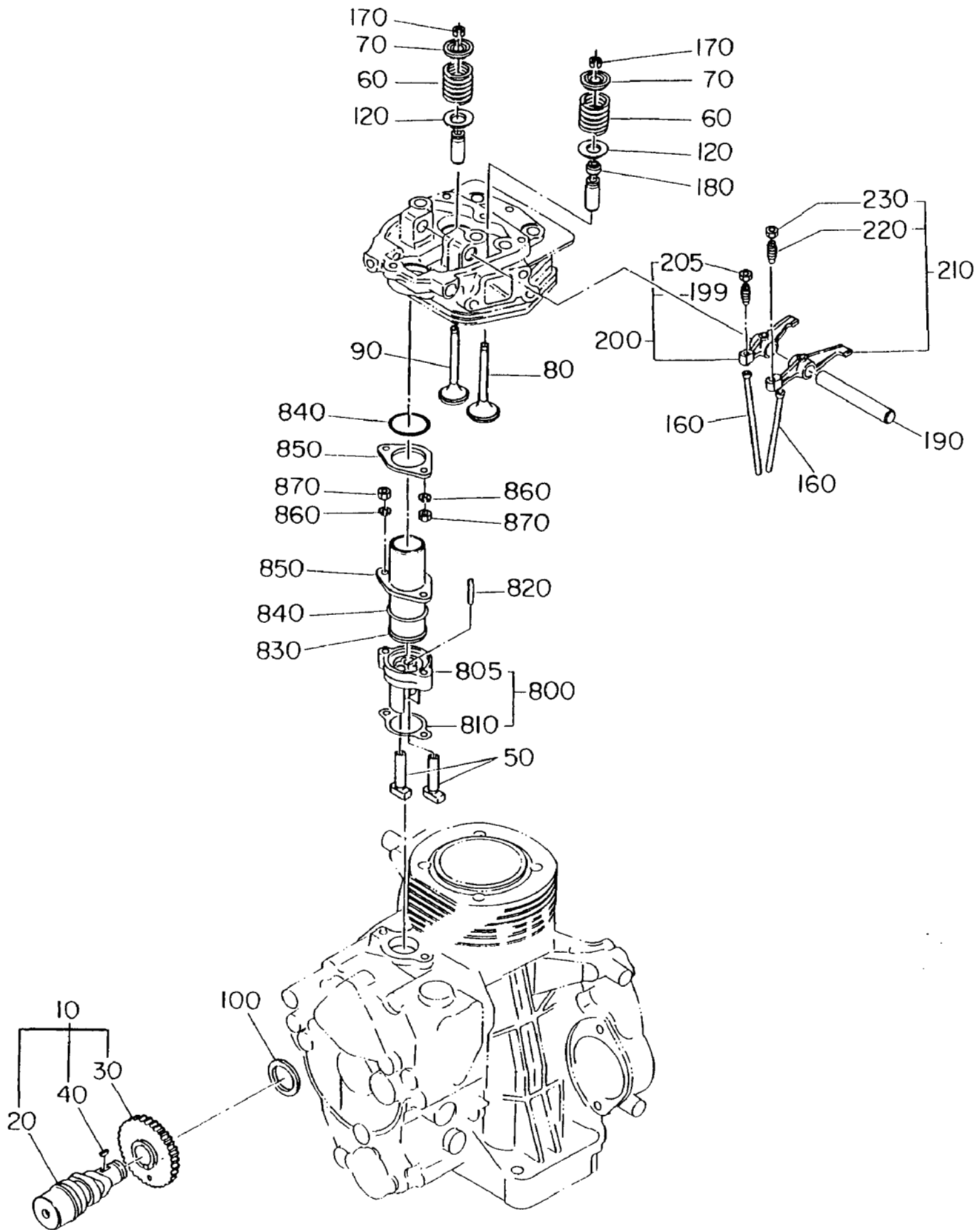

INTAKE, EXHAUST

93/09/21

REF. NO.	PART NUMBER		PART NAME		CODE NO. FROM - TO	QTY	REMARKS	INTERCHANGEABLE PART NUMBER	FIG. NO.
		PART NUMBER		SPEC. NO.					
10	228-31604-00		CAMSHAFT AY		-	1			300
20	228-31604-01		CAMSHAFT CP		-	1			300
30	228-33222-01		CAMSHAFT GEAR CP		-	1			300
40	005-32042-01		WOODRUFF KEY		-	1			300
50	228-33301-03		TAPPET		-	2			300
55	228-35561-03		RELEASE LEVER		-	1			300
60	228-33601-03		VALVE SPRING		-	2			300
70	228-33701-03		SPRING RETAINER		-	2			300
80	228-33401-13		INTAKE VALVE		-	1			300
90	228-33501-03		EXHAUST VALVE		-	1			300
100	023-02000-20		SPACER		-	1	T=0.8 SELECTIVE AY		300
	023-02000-30		SPACER		-	1	T=1.0 SELECTIVE AY		300
	023-02000-40		SPACER		-	1	T=1.2 SELECTIVE AY		300
160	231-35005-03		PUSH ROD		-	2			300
170	228-33801-03		RETAINER LOCK		-	4			300
180	228-35003-03		VALVE STEM SEAL		-	1			300
190	228-35004-03		ROCKER SHAFT		-	1			300
200	228-36201-01		EXHAUST ROCKERARM CP		-	1			300
220	014-90600-80		ADJUSTING SCREW		-	1			300
230	017-00600-80		NUT		-	1			300
210	228-36401-01		INTAKE ROCKER ARM CP		-	1		228-36301-01	300
240	014-90600-80		ADJUSTING SCREW		-	1			300
250	017-00600-80		NUT		-	1			300
310	228-30105-01		MUFFLER CP		-	1			300
320	228-34201-11		MUFFLER COVER CP		-	1			300
530	228-35006-03		GASKET (MUFFLER)		-	2			300
350	002-18080-00		NUT		-	2			300
350	002-19080-00		NUT		-	2			300
360	011-00600-10		FLANGE BOLT		-	4			300
380	003-20080-00		SPRING WASHER		-	4			300
510	228-32801-00		AIR CLEANER AY		-	1			350
- 7	228-32805-08		PACKING		-	1			350
520	228-32803-08		ELEMENT		-	1			350
525	228-32802-08		ELEMENT		-	1		228-32801-07	350
600	228-92306-03		LABEL (AIR CLEANER)		-	1			350
830	231-35603-11		PUSH ROD SLEEVE		-	1			300

INTAKE, EXHAUST GROUP

FIG. 310

MUFFLER & AIR CLEANER

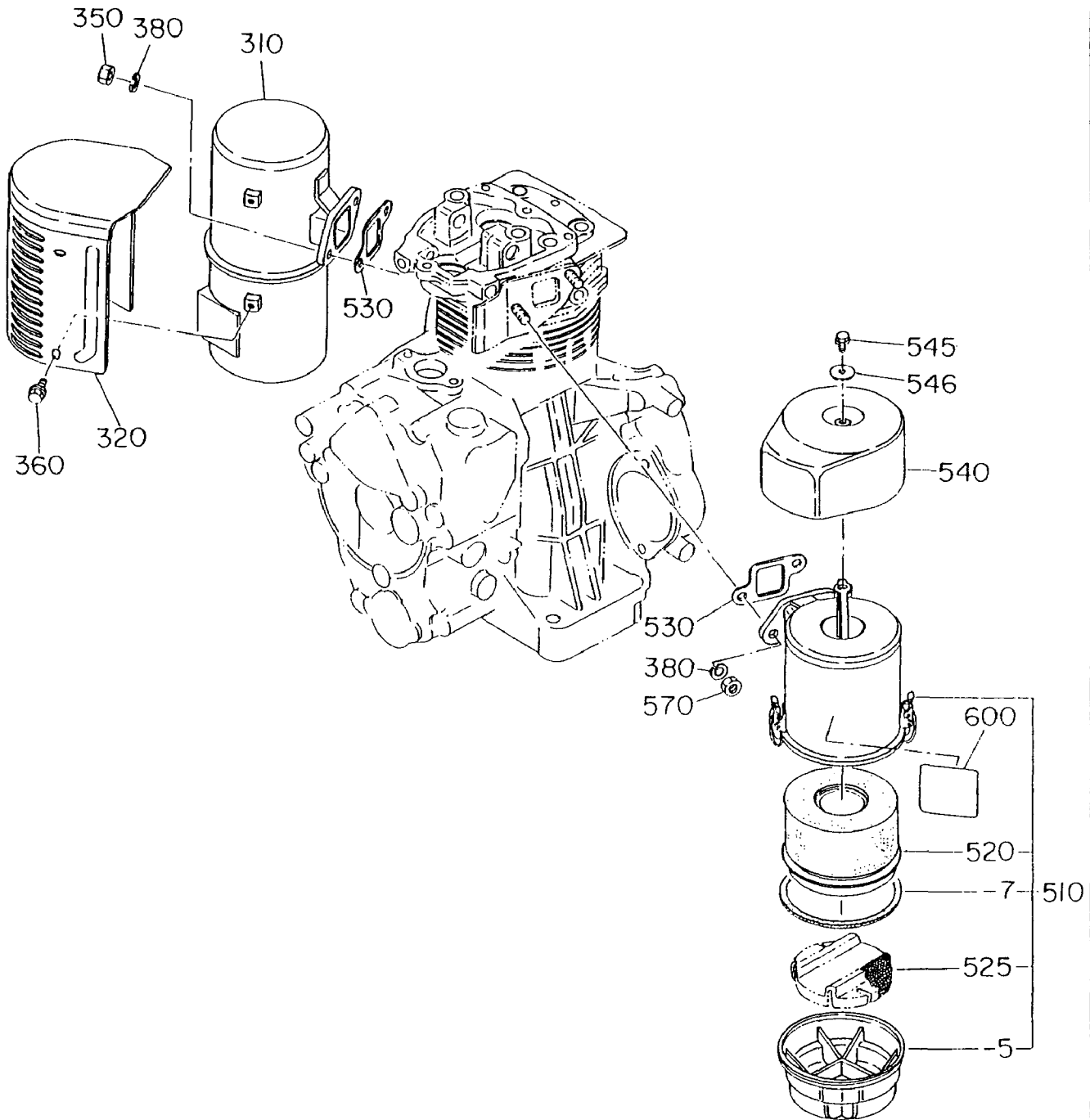

REF. NO.	PART NUMBER		PART NAME		CODE NO. FROM - TO	QTY	REMARKS	INTERCHANGEABLE PART NUMBER	FIG. NO.
				SPEC. NO.					
850	228-35801-01		PLATE CP, PUSH ROD		-	2			300
840	024-03200-20		O RING		-	2			300
805	228-35701-13		TAPPET GUIDE		-	1		228-35701-11	300
810	228-35013-03		GASKET (TAPPET GUIDE)		-	1			300
860	003-20060-00		SPRING WASHER		-	4			300
870	002-18060-00		NUT		-	4			300

FIG. 400

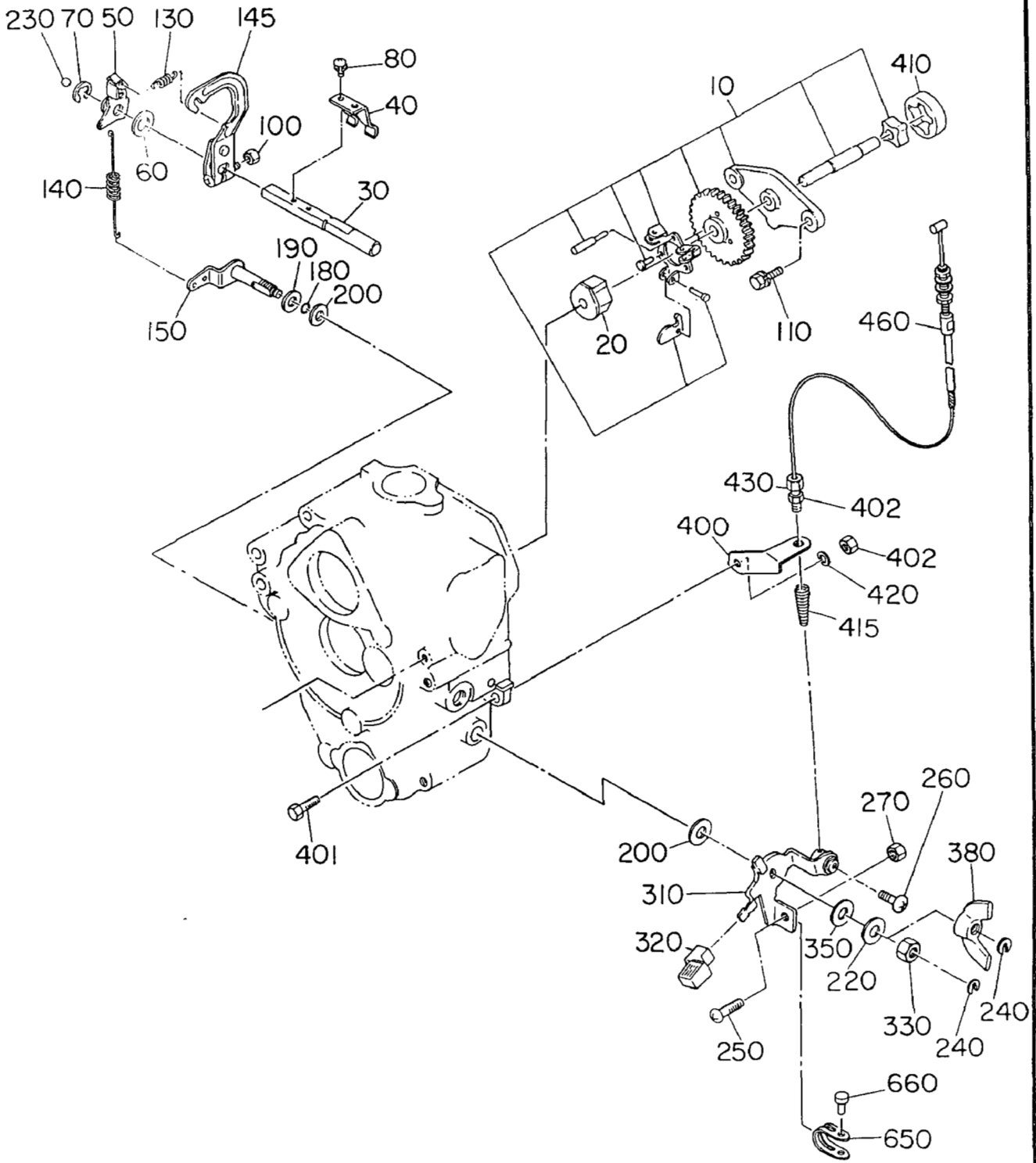

GOVERNOR. OPERATION

93/09/21

REF. NO.	PART NUMBER		PART NAME		CODE NO. FROM - TO	QTY	REMARKS	INTERCHANGEABLE PART NUMBER	FIG. NO.
		PART NUMBER		SPEC. NO.					
10	228-41701-30			GOVERNOR PLATE AY	-	1			400
20	228-41910-01			GOVERNOR SLEEVE CP	-	1			400
30	228-42201-03			GOVERNOR SHAFT	-	1			400
40	228-42101-23			GOVERNOR YOKE	-	1			400
50	228-42302-03			GOVERNOR LEVER 1	-	1			400
60	003-10100-00			WASHER	-	1			400
70	003-13080-00			CLIP	-	1			400
80	004-35051-20			SCREW AND WASHER AY	-	2			400
100	002-18060-00			NUT	-	2			400
110	001-13062-00			BOLT AND WASHER AY	-	2			400
130	228-45001-33			START SPRING	-	1			400
140	228-42501-23			GOVERNOR SPRING	-	1			400
145	228-42310-02			GOVERNOR LEVER 2 UN	-	1			400
150	228-42904-02			CONTROL LINK UN	-	1			400
180	006-26100-50			O RING	-	1			400
190	023-00800-10			SPACER	-	1			400
200	021-70800-10			FRICTION WASHER	-	1			400
210	020-00800-10			WASHER	-	1			400
220	020-00800-50			WASHER	-	1			400
230	045-00600-10			STEEL BALL	-	1			400
250	004-31063-50			SCREW	-	1			400
260	004-31051-20			SCREW	-	1			400
270	002-18060-00			NUT	-	1			400
310	231-43311-01			SPEED CONTROL 1 CP	-	1			400
320	228-45003-03			KNOB	-	1			400
330	017-90800-12			WING NUT	-	1			400
400	228-44201-01			WIRE BRACKET 1	-	1			400
401	001-65061-60			BOLT	-	1			400
402	002-18060-00			NUT	-	1			400
410	228-63902-03			OIL PUMP(OUTER)	-	1			400
415	228-46002-11			RETURN SPRING CP	-	1			400
420	003-20060-00			SPRING WASHER	-	1			400
430	014-90600-40			ADJUSTING SCREW	-	1			400
650	228-45004-03			LOCK PLATE	-	1			400
660	033-00500-10			RIVET.	-	1			400

COOLING, STARTING GROUP

FIG. 500

for RECOIL type

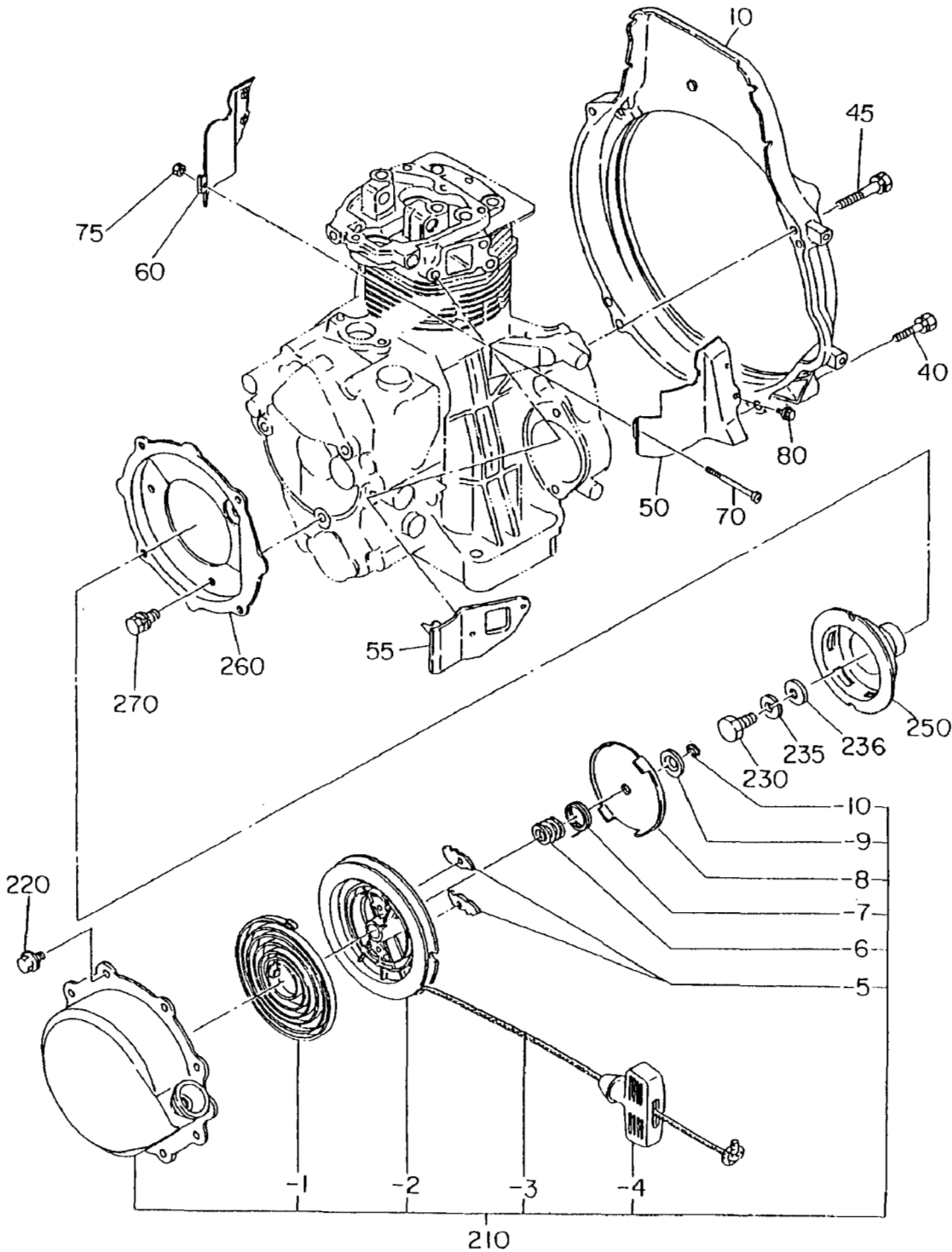
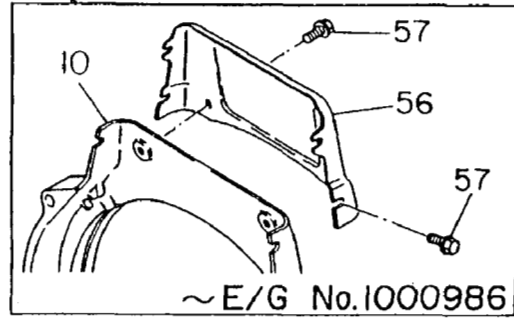

COOLING, STARTING

93/09/21

REF. NO.	PART NUMBER		PART NAME		CODE NO. FROM - TO	QTY	REMARKS	INTERCHANGEABLE PART NUMBER	FIG. NO.
		PART NUMBER		SPEC. NO.					
10		231-51201-13		BLOWER HOUSING	-	1		231-51202-03	500
40		001-13084-00		BOLT AND WASHER AY	-	2			500
45		001-13085-50		BOLT AND WASHER AY	-	2			500
50		231-52601-12		CYLINDER BAFFLE 1 UN	-	1			500
60		231-52701-12		CYLINDER BAFFLE 2 UN	-	1			500
70		014-00500-40		SCREW (PAN HEAD)	-	1			500
80		011-00600-20		FLANGE BOLT	-	4			500
75		002-17050-00		NUT	-	1			500
210		228-50101-00		RECOIL STARTER AY	-	1			500
- 1		106-50116-08		SPIRAL SPRING	-	1			500
- 2		107-50121-08		REEL CP	-	1			500
- 3		228-50110-08		ROPE	-	1			500
- 4		206-50101-08		STARTER KNOB	-	1			500
- 5		106-50128-18		RATCHET	-	2			500
- 6		106-50132-08		FRICTION SPRING	-	1			500
- 7		106-50136-18		RETURN SPRING	-	1			500
- 8		106-50144-08		FRICTION PLATE	-	1			500
- 9		106-50185-08		THRUST WASHER	-	1			500
- 10		106-50186-08		CLIP	-	1			500
220		011-00600-10		FLANGE BOLT	-	4			500
250		228-54201-21		STARTING PULLEY CP	-	1			500
230		001-66102-00		BOLT	-	1			500
235		003-20100-00		SPRING WASHER	-	1			500
280		980-30110-70		WASHER (11.5X23X4)	-	1		803011070	500
260		228-55201-02		RECOIL COVER UN	-	1			500
370		001-13082-00		BOLT & WASHER AY	-	3			500

FUEL, LUBRICANT GROUP

FIG. 600

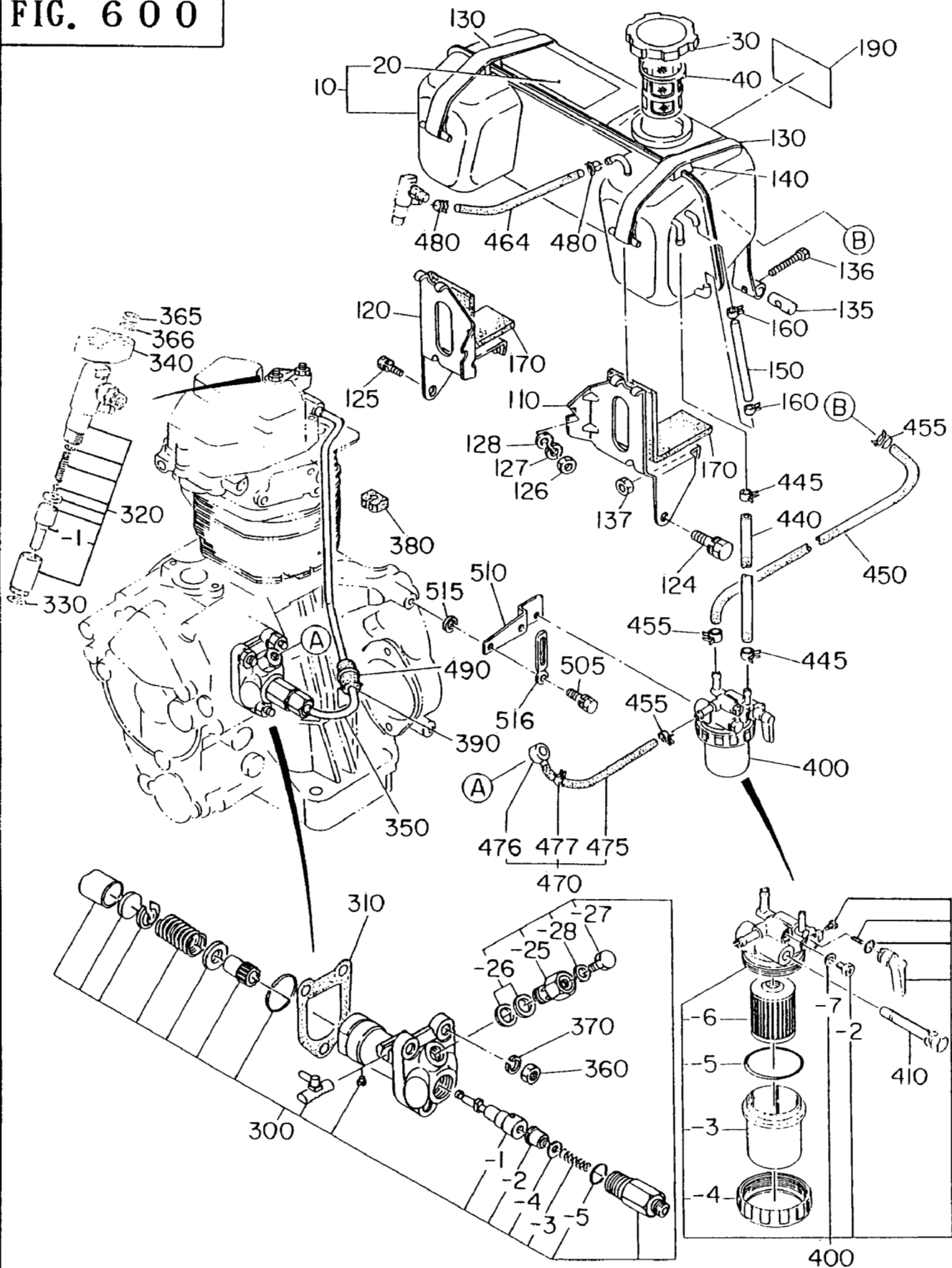

FUEL, LUBRICANT

93/09/21

REF. NO.	PART NUMBER		PART NAME		CODE NO. FROM - TO	QTY	REMARKS	INTERCHANGEABLE PART NUMBER	FIG. NO.
		PART NUMBER		SPEC. NO.					
10	228-60102-41		FUEL TANK CP		-	1			600
190	231-91712-03		LABEL (TRADE MARK)		-	1			600
20	228-91908-03		LABEL (INSTRUCTION)		-	1			600
30	043-04300-15		FUEL TANK CAP CP		-	1			600
40	064-13600-10		FUEL FILTER		-	1			600
110	231-61601-11		TANK BRACKET 1 CP		-	1			600
120	231-61701-11		TANK BRACKET 2 CP		-	1			600
124	001-13082-50		BOLT AND WASHER AY		-	1			600
130	228-65510-01		TANK BAND CP		-	2			600
125	001-13082-00		BOLT & WASHER AY		-	1			600
135	228-65601-11		PIN CP, TANK BAND		-	2			600
140	228-65001-13		BAND GUIDE		-	2			600
170	228-65002-03		FELT		-	2			600
440	085-14500-00		RUBBER PIPE		-	1	4.5X9XM		600
150	085-00500-00		VINYL PIPE		-	1	5X8XM		600
445	056-10800-10		HOSE CLAMP		-	2			600
136	001-66064-50		BOLT		-	2			600
137	002-18060-00		NUT		-	2			600
190	002-38060-00		FLANGE NUT		-	2			600
480	056-10800-10		HOSE CLAMP		-	4			600
128	003-10080-00		WASHER		-	2			600
300	228-63101-00		INJECTION PUMP AY		-	1			600
- 1	228-63102-08		PLUNGER AY		-	1			600
- 2	228-63103-08		DELIVERY VALVE		-	1			600
- 3	222-63104-08		SPRING DELIVERY VALV		-	1			600
- 4	222-63105-08		GASKET		-	1			600
- 5	228-63105-08		O RING		-	1			600
- 25	228-63112-08		BOLT		-	1			600
- 26	222-63116-08		GASKET		-	2			600
- 27	228-63113-08		BOLT		-	1			600
- 28	211-63212-08		GASKET 50623-180		-	1			600
310	228-65017-03		GASKET (INJ. PUMP)		-	1	T=0.1 SELECTIVE AY		600
	228-65022-03		GASKET (INJ. PUMP)		-	1	T=0.2 SELECTIVE AY		600
	228-65018-03		GASKET (INJ. PUMP)		-	1	T=0.3 SELECTIVE AY		600
320	228-63201-10		NOZZLE AY		-	1			600
- 1	228-63211-08		NOZZLE		-	1			600

FUEL, LUBRICANT GROUP

FIG. 600

for D, B type

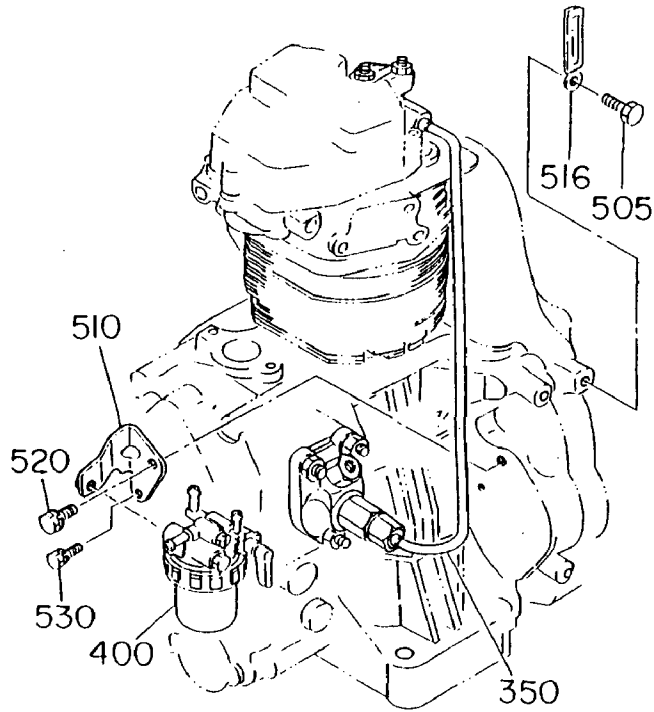

CODE NO. -0000

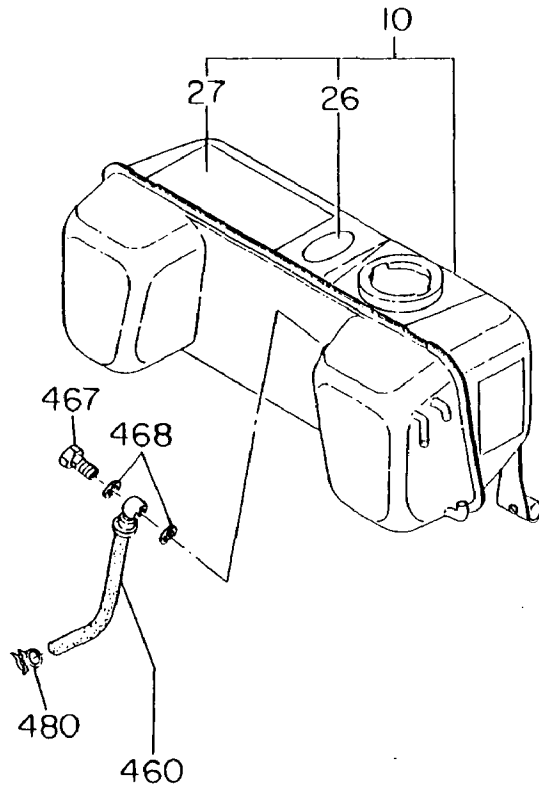

FUEL, LUBRICANT

93/09/21

REF. NO.	PART NUMBER		PART NAME		CODE NO. FROM - TO	QTY	REMARKS	INTERCHANGEABLE PART NUMBER	FIG. NO.
		PART NUMBER		SPEC. NO.					
330		228-65004-03		GASKET (NOZZLE)	-	1			600
340		243-66001-01		BRACKET CP, NOZZLE 1	-	1			600
360		002-18080-00		NUT	-	5			600
370		003-20080-00		SPRING WASHER	-	5			600
400		228-62106-10		FUEL FILTER AY	-	1			600
- 3		243-62101-08		CUP	-	1			600
- 4		228-62108-08		RING NUT	-	1			600
- 5		228-62109-08		O RING	-	1			600
- 6		228-62110-08		ELEMENT	-	1			600
410		001-13086-50		BOLT AND WASHER AY	-	1			600
350		231-63301-01		INJECTION PIPE CP	-	1			600
390		*****		RUBBER PIPE					
		228-65020-03		DY410YS0000	-	1			600
380		222-65006-03		GROMMET	-	1			600
475		085-10600-00		RUBBER PIPE	-	1	6X12XM		600
470		228-62610-01		FUEL PIPE 10 CP	-	1			600
		228-62611-01		DY410YS0000	-	1			600
450		085-10600-00		RUBBER PIPE	-	1	6X12XM		600
516		150-75201-03		CLAMP	-	1			600
		056-60001-70		DY410YS0000	-	1			600
505		001-10061-00		BOLT&WASHER AY	-	1			600
515		*****		WASHER					
		020-00601-10		DY410YS0000	-	1			600
510		228-67602-01		FUEL F. BRACKET CP	-	1			600
		228-67630-01		DY410YS0000	-	1			600
520		001-13082-00		BOLT & WASHER AY	-	1			600
530		001-13061-80		BOLT AND WASHER AY	-	1			600
476		052-10500-12		BANJO	-	1			600
477		056-11100-20		HOSE CLAMP	-	1			600
464		085-14500-00		RUBBER PIPE	-	1	4.5X9XM		600
455		056-11100-20		HOSE CLAMP	-	3			600

FIG. 700

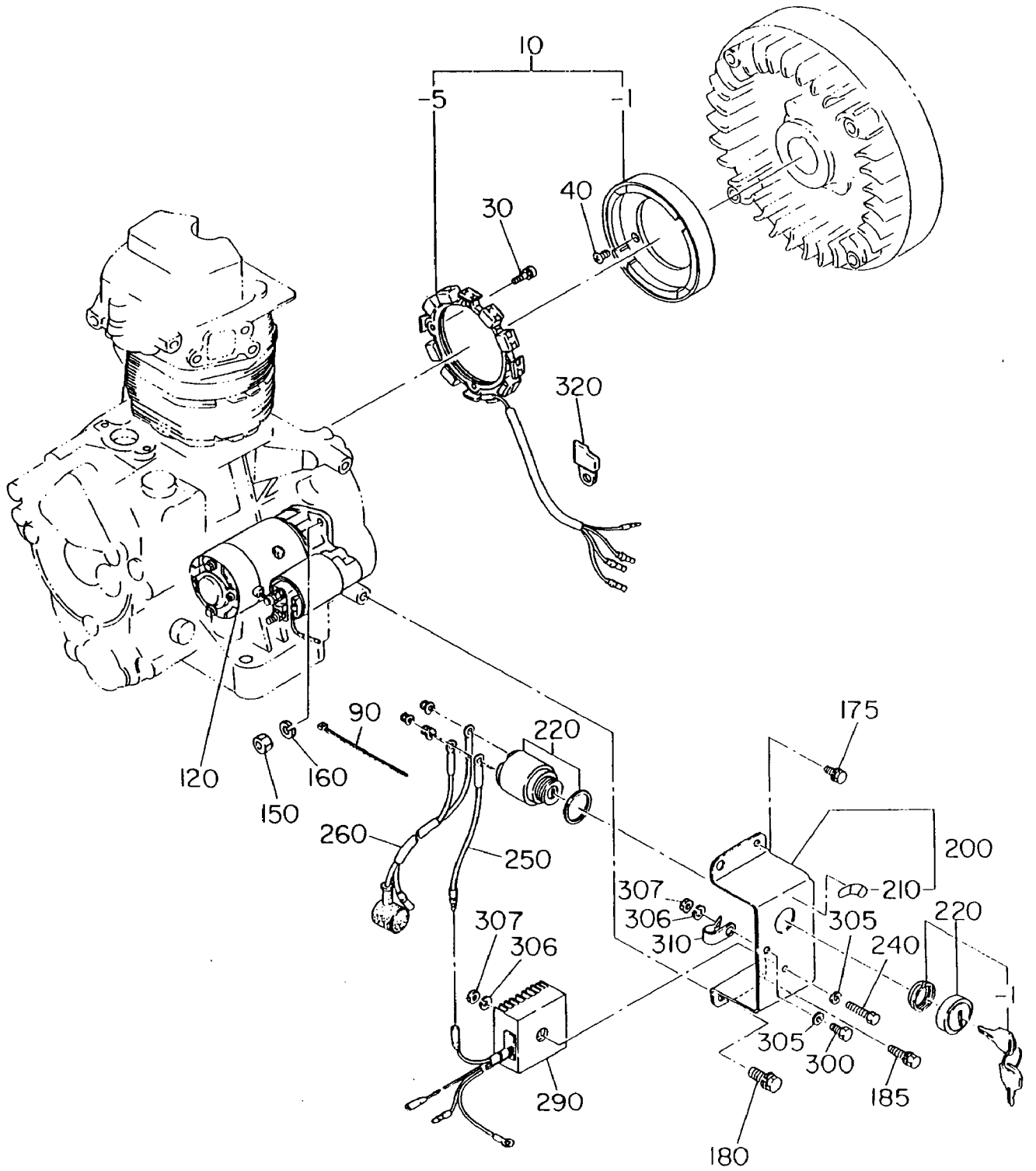

ELECTRIC DEVICE

93/09/21

REF. NO.	PART NUMBER		PART NAME		CODE NO. FROM - TO	QTY	REMARKS	INTERCHANGEABLE PART NUMBER	FIG. NO.
		PART NUMBER		SPEC. NO.					
10	*****		GENERATOR CP						
		228-70401-01	DY410YS0000	-	1				700
- 1	*****		FLYWHEEL						
		228-70401-08	DY410YS0000	-	1				700
- 5	*****		STATOR CP						
		228-70402-08	DY410YS0000	-	1				700
30	*****		SCREW AND WASHER AY						
		004-35041-20	DY410YS0000	-	4				700
40	*****		SCREW						
		004-11061-00	DY410YS0000	-	3				700
60	*****		CLAMP CP						
		228-75002-01	DY410YS0000	-	1				700
120	*****		STARTING MOTOR AY						
		210-70502-10	DY410YS0000	-	1				700
- 2	*****		BRUSH +						
		210-70539-08	DY410YS0000	-	2				700
- 3	*****		BRUSH SPRING						
		210-70541-08	DY410YS0000	-	4				700
- 4	*****		BRUSH HOLDER						
		210-70538-08	DY410YS0000	-	1				700
- 6	*****		ARMATURE						
		210-70532-08	DY410YS0000	-	1				700
- 7	*****		PINION 2114-75005						
		210-70544-08	DY410YS0000	-	1				700
- 8	*****		PINION STOPPER SET						
		210-70534-08	DY410YS0000	-	1				700
- 9	*****		GEAR CASE AY						
		210-70545-08	DY410YS0000	-	1				700
- 10	*****		BRUSH -						
		210-70540-08	DY410YS0000	-	2				700
- 11	*****		REAR COVER AY						
		210-70537-18	DY410YS0000	-	1				700
- 12	*****		REAR COVER METAL						
		210-70542-08	DY410YS0000	-	1				700
- 13	*****		BLIND COVER						
		210-70551-08	DY410YS0000	-	1				700

ELECTRIC DEVICE GROUP(DS,BS)

FIG. 700

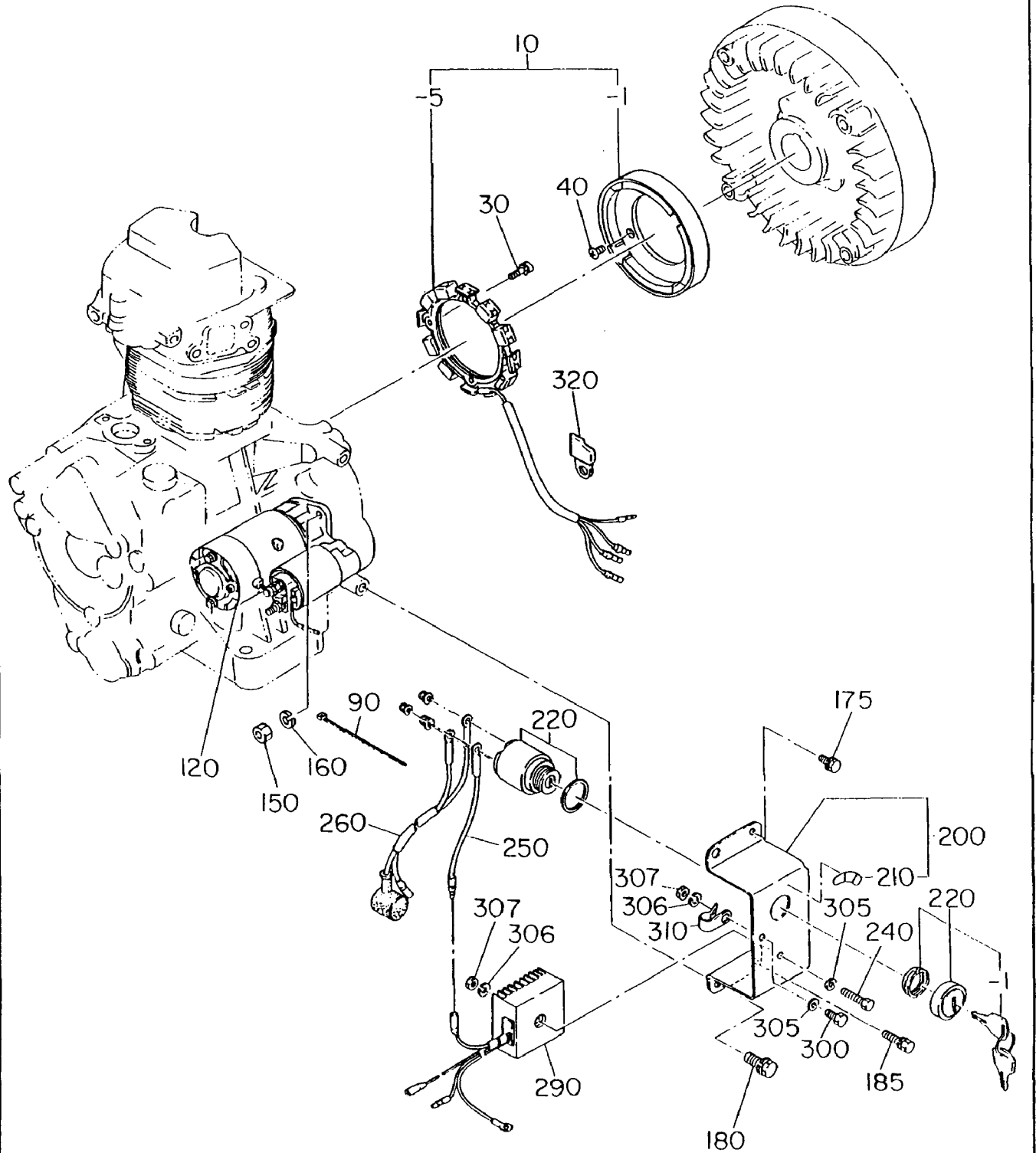

ELECTRIC DEVICE

93/09/21

REF. NO.	PART NUMBER		PART NAME		CODE NO. FROM - TO	QTY	REMARKS	INTERCHANGEABLE PART NUMBER	FIG. NO.
		PART NUMBER		SPEC. NO.					
- 14	*****		SHIFT LE	2114-9652					
		210-70546-08		DY410YS0000	-	1			700
- 15	*****		M SWITC AY						
		210-70548-08		DY410YS0000	-	1			700
- 17	*****		BOLT						
		210-70549-08		DY410YS0000	-	2			700
- 25	*****		THRUST WASHER KIT						
		210-70533-08		DY410YS0000	-	1			700
- 26	*****		FIELD COIL						
		210-70535-08		DY410YS0000	-	1			700
- 27	*****		SCREW						
		210-70508-08		DY410YS0000	-	4			700
- 28	*****		CENTER PLATE						
		210-70543-08		DY410YS0000	-	1			700
- 29	*****		GEAR CASE METAL						
		210-70547-08		DY410YS0000	-	1			700
- 30	*****		DUST COVER KIT						
		210-70550-18		DY410YS0000	-	1			700
130	*****		NUT						
		002-18080-00		DY410YS0000	-	2			700
140	*****		SPRING WASHER						
		003-20080-00		DY410YS0000	-	2			700
150	*****		WIRE 1 CP (MOTOR)						
		228-73101-01		DY410YS0000	-	1			700
160	*****		WIRE 2 CP						
		228-73108-01		DY410YS0000	-	1			700
170	*****		WIRE BAND						
		056-30000-20		DY410YS0000	-	1			700
220	*****		SWITCH						
		066-00001-40		DY410YS0000	-	1			700
- 1	*****		KEY						
		066-00002-10		DY410YS0000	-	1			700
500	*****		CONTROL BOX CP						
		228-40601-11		DY410YS0000	-	1			700
510	*****		LABEL (STARTER SWITCH						
		073-20010-90		DY410YS0000	-	1			700

ELECTRIC DEVICE GROUP(DS,BS)

FIG. 700

120

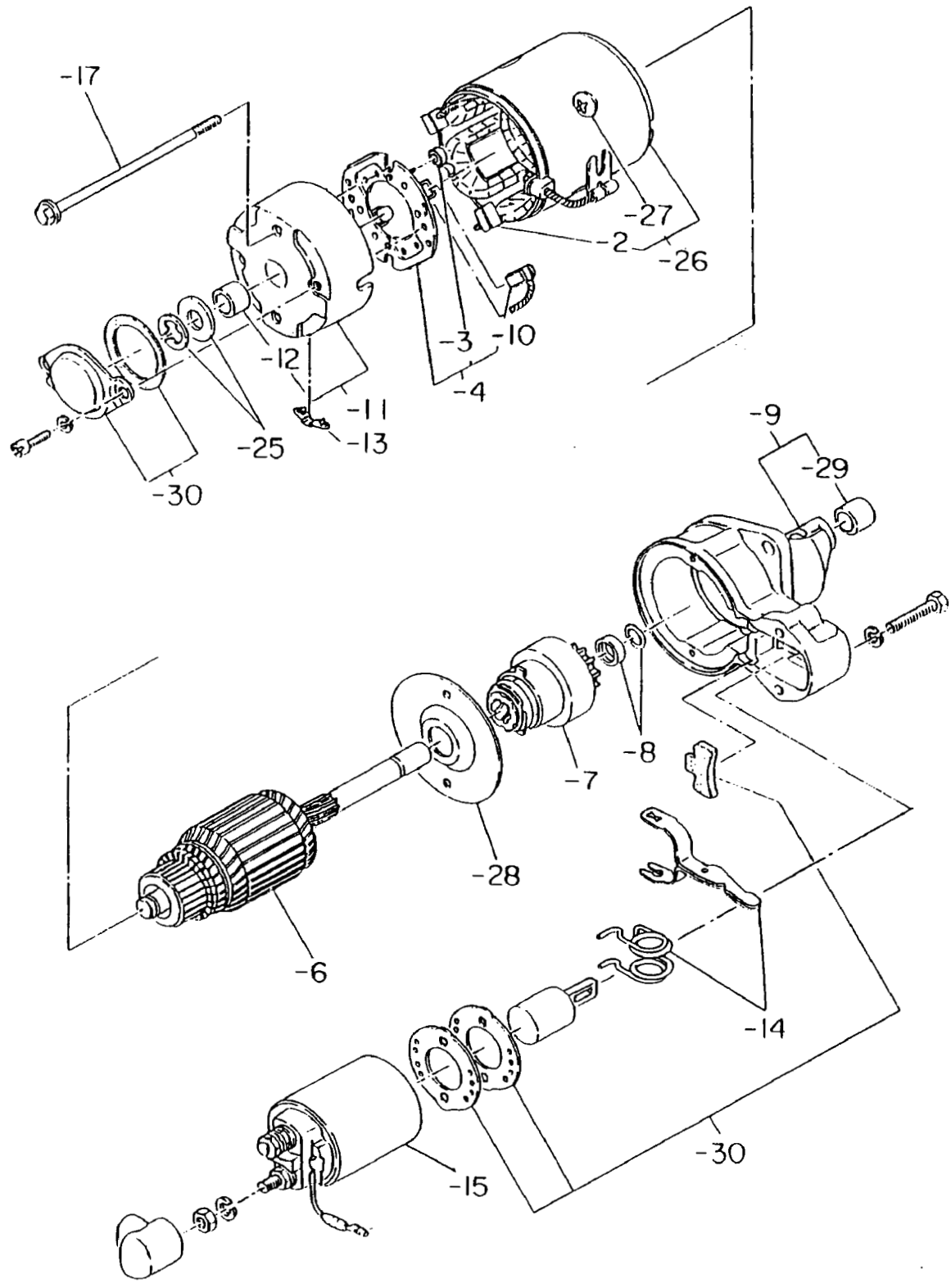

ELECTRIC DEVICE

93/09/21

REF. NO.	PART NUMBER		PART NAME		CODE NO. FROM - TO	QTY	REMARKS	INTERCHANGEABLE PART NUMBER	FIG. NO.
		PART NUMBER		SPEC. NO.					
180	*****		BOLT & WASHER AY						
	001-13082-00			DY410YS0000	-	1			700
310	*****		CLAMP						
	056-61000-21			DY410YS0000	-	1			700
175	*****		BOLT AND WASHER AY						
	001-13061-20			DY410YS0000	-	1		001-14061-20	700
240	*****		BOLT						
	001-65062-50			DY410YS0000	-	1			700
300	*****		BOLT						
	001-65061-00			DY410YS0000	-	1			700
306	*****		SPRING WASHER						
	003-20060-00			DY410YS0000	-	2			700
305	*****		WASHER						
	003-10060-00			DY410YS0000	-	2			700
307	*****		NUT						
	002-17060-00			DY410YS0000	-	2			700
290	*****		REGULATOR CP						
	228-71901-01			DY410YS0000	-	1			700

ACCESSORIES, LABEL GROUP

FIG. 900

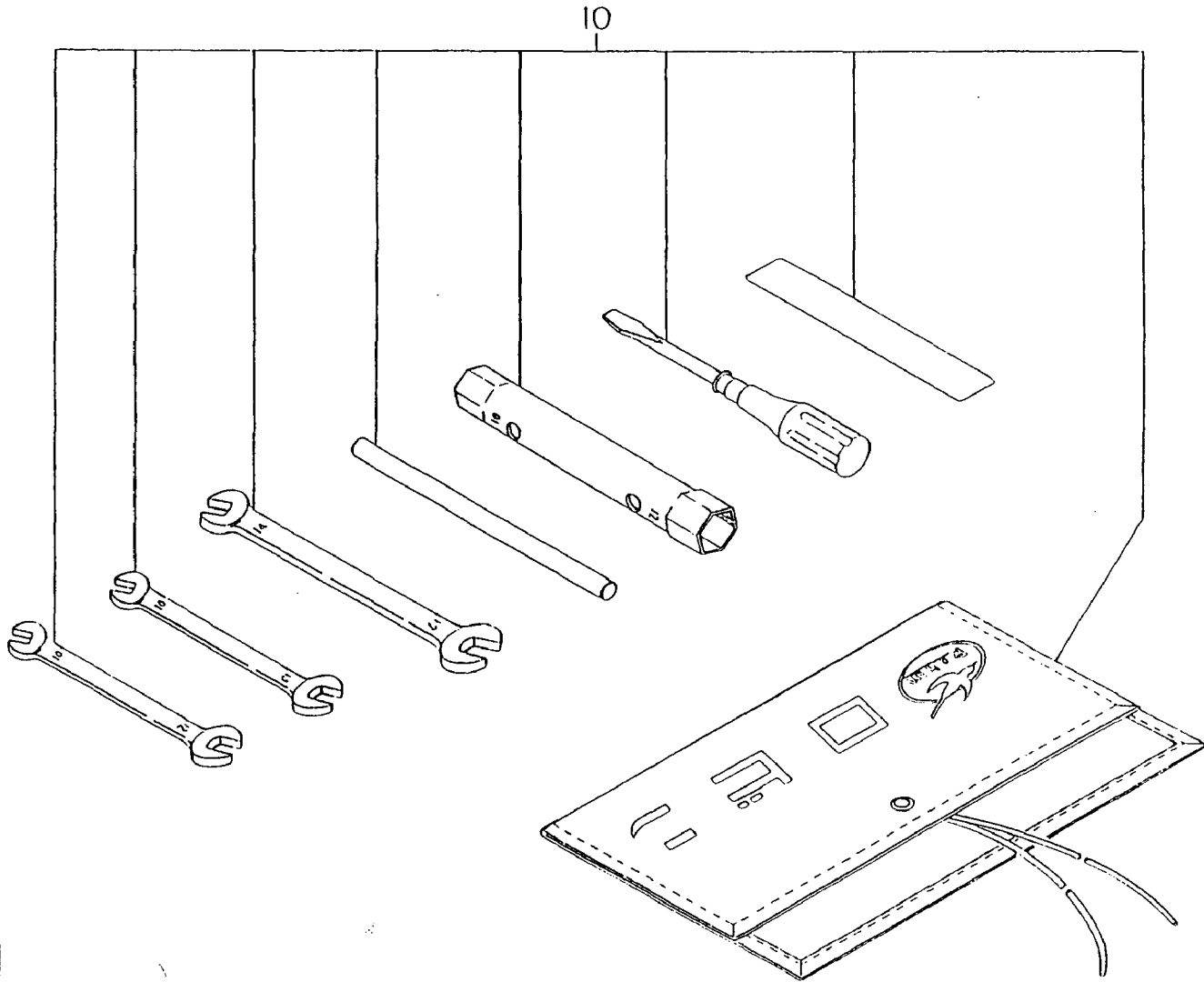

ACCESSORIES, LABEL

93/09/21

REF. NO.	PART NUMBER		PART NAME		CODE NO. FROM - TO	QTY	REMARKS	INTERCHANGEABLE PART NUMBER	FIG. NO.
		PART NUMBER		SPEC. NO.					
10		228-90301-10		ACCESSORY TOOLS KIT	-	1			900

— NOTES —



Robin America, Inc.

940 Lively Blvd., Wood Dale, IL 60191 • Tel: (708) 350-8200 • Fax: (708) 350-8212